

*Columbia Gas of Kentucky*  
*Columbia Gas of Maryland*  
*Columbia Gas of Ohio*  
*Columbia Gas of Pennsylvania*  
*Columbia Gas of Virginia*

NiSource Companies

## **STANDARDS FOR CUSTOMER SERVICE LINES, METERS, AND SERVICE REGULATORS**

(Plumber's Guide)

**Revised: 10/01/2010**

## PREFACE

The information included in this booklet is intended as a guide for installation, inspection, and testing of plastic two-inches and under **customer service lines and meter setting installations**. This is only a guide, and may not include all applicable codes, regulations, policies and procedures, or revisions.

*NOTE: The reader should be aware that the printed copies of this document may not be current and electronic copies of this document that can be viewed at the Columbia Gas Web Sites are the most current and accurate version.*

*NOTE: An asterisks (\*) following a section title indicates that explanatory material and excerpts from relevant codes can be found in Appendix A, and is numbered to correspond with the applicable guide paragraphs.*

### Columbia Gas Standards

"Standards for Customer Service Lines, Meters, and Service Regulators" (Plumber's Guide); New Tap and Meter Process, Materials for Customer Service Lines, Standard Drawings for Meter Settings, Operator Qualification Card, and Plumber's Guide Revision Proposal Form are available for Ohio on the internet at: [www.columbiagasohio.com/](http://www.columbiagasohio.com/) and for Pennsylvania and Maryland at: [www.columbiagaspa.com/](http://www.columbiagaspa.com/)

#### **Q: How does a plumber or builder get a copy of the Plumber's Guide, Material Manual, and related information?**

**A:** Launch your computer internet web browser, and:

For Ohio

Type <http://www.columbiagasohio.com/>

Then click:

- "Your Business"
- "Information for Plumbers and Builders"
- "Standards and Materials",  
"Operator Qualification",  
"Prefab and Meter Setting Drawings", or  
"New Business Services"

For Pennsylvania

Type <http://www.columbiagaspa.com/>

Then click:

- "Plumber Information"
- Left-side links:  
"Pipeline Installation Standards Guide",  
"Approved Materials Manual",  
or
- Body links

#### **Q: How does a customer find a plumber who has met the federal guidelines to be Operator Qualified?**

**A:** The list is posted on the Company's website, and is updated weekly. It is sorted by City and State.

Follow the steps above. There are links to the Operator Qualification lists.

### DOT Part 192

The Code of Federal Regulations Title 49, Department of Transportation Part 192, "Transportation of Natural Gas and Other Gas by Pipeline: Minimum Federal Safety Standards" (available on the internet at: [www.gpoaccess.gov/](http://www.gpoaccess.gov/)); Gas Company policies and procedures; and local codes shall be followed, and will be the basis for Gas Company inspection, testing, and/or approval when installing **service lines and meter settings**.

**Standards for Customer Service Lines, Meters, and Service Regulators (Plumbers Guide)**

---

**Fuel Gas Code**

The National Fuel Gas Code (ANSI Z223.1/NFPA 54) shall be followed. It is a national standard, and will be the basis for Gas Company inspection, testing, and/or approval for **house lines and appliances**. The code can be purchased from:

- American Gas Association (AGA), (301) 617-7819, internet: [www.aga.org](http://www.aga.org); or  
Techstreet (techstreet.service@thomson.com)  
Phone: 800-699-9277      FAX: 734-913-3946      Int'l: 734-913-3939  
Mail Order: 777 E. Eisenhower Parkway, Ann Arbor, MI 48108

Other codes, such as the International Fuel Gas Code, may be enforced by local building code inspectors, and adherence to them for those inspectors may be required. The more stringent code must always be followed. When in doubt, contact the Gas Company and the Authority having jurisdiction to clarify before proceeding with the work.

**Manufactured Homes Part 3280**

The Code of Federal Regulations Title 24, Housing and Urban Development Part 3280, "Manufactured Home Construction and Safety Standards"; Gas Company policies and procedures; and local codes shall be followed and will be the basis for Gas Company inspection, testing, and/or approval of **Manufactured Homes**.

**Phone Numbers**

Gas Company

Emergency:

Kentucky - 800-432-9515

Maryland - 888-460-4332

Ohio – 800-282-0157

Pennsylvania - 888-460-4332

Virginia – 800-544-5606

Service Inquiries (DirectLink):

Kentucky - 800-432-9345

Maryland - 888-460-4332

Ohio – 800-344-4077

Pennsylvania – 888-460-4332

Virginia – 800-543-8911

New Business – 800-440-6111

Call Before You Dig (One Call)

National One Call – 811

Kentucky BUD – 800-752-6007

Maryland Miss Utility – 800-257-7777

Ohio OUPS – 800-362-2764

Pennsylvania Miss Utility – 800-242-1776

Virginia Miss Utility - 800-552-7001

## REVISIONS TO PREVIOUS EDITION

**This guide replaces, in its entirety; the standard dated January 7, 2008.**

### **Changes\* to the previous edition include:**

Extensive wording changes and updates have been made to the manual. Please review the entire manual.

The major topics changed in this edition are:

- Several service line and meter setting paragraphs changes
- Section 1.1 (f) & (g) – the scope has been reworded
- Section 1.3.2 (c) – updated changes to state-specific gas service arrangements
- Section 1.5 – updated the ownership change
- Section 2.3.2 – required welding qualification
- Section 2.3.5 – required thread sealant approved for natural gas use
- Section 3.1.5(a) – clarified regulator venting
- Section 3.2.1(b) & (c) – specified to move inside meter setting to the outside
- Section 3.3.3 – added house line identification for manifolds
- Section 4.1.4 – moved the records section to Section 4.6
- Section 4.1.5 – moved leak detection to Section 4.4
- Section 4.2.4(a)2 – included Ohio house line termination requirements
- Section 4.4.1 – added new leak detection requirements
- Section 4.5 – moved purging from Section 4.4
- Section 4.5.3 (a) & (b) – added additional purge information
- Section 4.5.4 – included a new smell check requirement for odorant
- Section 4.6 – moved Records section from Section 4.1.4
- Section A.2.3.2 – provided additional information on welding qualification
- Section A.3.1.5 – provided additional information on regulator vent clarification
- Section A.3.2 – provided additional information on meter location clarification
- Section A.3.6.1 – provided additional information on high pressure setting notification
- Section D Sketch 5 – edited to remove that the vent box lid be marked, and specify the foundation casing be sleeved or grouted

---

\* Due to the extensive nature of the revision, vertical marginal change lines have been omitted

## TABLE OF CONTENTS

NOTE: An asterisk (\*) indicates explanatory information on the paragraph can be found in Appendix A.

<b>PART 1 - GENERAL .....</b>	<b>1</b>
1.1 SCOPE .....	1
1.2 CUSTOMER ADVISORY SERVICE .....	1
1.3 REQUEST FOR GAS SERVICE .....	2
1.3.1 Information Required.....	2
1.3.2 Arrangements for Establishing Gas Service* .....	2
1.4 CUSTOMER CHARGES .....	3
1.5 OWNERSHIP AND RESPONSIBILITY .....	3
1.6 DEFINITIONS .....	4
<b>PART 2 - CUSTOMER SERVICE LINES .....</b>	<b>6</b>
2.1 GENERAL REQUIREMENTS GOVERNING CUSTOMER SERVICE LINES.....	6
2.1.1 One service line to one building.....	6
2.1.2 Existing Service Lines .....	6
2.1.3 Property Lines .....	6
2.1.4 Split Service Lines .....	6
2.1.5 Service Classifications .....	6
2.2 LOCATION OF SERVICE .....	6
2.2.1 Service line routing .....	6
2.2.2 Service entrance.....	6
2.2.3 Installation of service lines under buildings* .....	7
2.3 MATERIALS .....	7
2.3.1 Plastic Pipe and Tubing.....	7
2.3.2 Steel Service Pipe* .....	8
2.3.3 Mechanical Fittings* .....	8
2.3.4 Plastic Fusion Fittings* .....	8
2.3.5 Screw Fittings.....	8
2.3.6 Risers.....	8
2.3.7 Meter Valves .....	9
2.4 SERVICE LINE SIZING* .....	9
2.4.1 Pipe Material .....	9
2.4.2 Available Service Line Pressure.....	9
2.4.3 Pressure Drop .....	9
2.4.4 Specific gravity and Heating Value of the gas .....	9
2.4.5 Length of Piping .....	9
2.4.6 Determining the Load.....	10
2.5 INSTALLATION.....	10
2.5.1 General .....	10
2.5.2 Trenching.....	10
2.5.3 Joining Pipe* .....	11
2.5.4 Bends.....	11
2.5.5 Tracer Wire .....	12
2.5.6 Backfilling .....	12

**Standards for Customer Service Lines, Meters, and Service Regulators (Plumbers Guide)**

2.6 INSERT RENEWAL OF EXISTING CUSTOMER SERVICE LINES ..... 12

    2.6.1 Material ..... 12

    2.6.2 Sizing ..... 12

    2.6.3 Installation ..... 13

    2.6.4 Anode Installation. .... 13

**PART 3 - METER SETTINGS..... 15**

    3.1 GENERAL ..... 15

        3.1.1 Meter..... 15

        3.1.2 Meter Valves and/or Bars ..... 15

        3.1.3 Meter Settings ..... 15

        3.1.4 Service Regulators\* ..... 15

        3.1.5 Regulator Relief Vent\* ..... 15

        3.1.6 Establishing gas service ..... 16

        3.1.7 Interruption of service..... 16

    3.2 METER SETTING LOCATION\* ..... 16

        3.2.1 General ..... 16

        3.2.2 Meter Setting Accessibility ..... 17

        3.2.3 Piping Accessibility ..... 17

        3.2.4 Ventilated Area..... 17

        3.2.5 Protected from Damage ..... 17

        3.2.6 Protect from Heat/Ignition\* ..... 17

        3.2.7 Regulator Location..... 18

    3.3 INSTALLATION..... 18

        3.3.1 Meter Valve..... 18

        3.3.2 Master Meter Valve..... 18

        3.3.3 Meter Tags..... 18

        3.3.4 Manifold Piping..... 18

        3.3.5 Meter Clearance ..... 18

        3.3.6 Plumb and Level..... 19

        3.3.7 Electrical Isolation, Grounding, and Bonding ..... 19

        3.3.8 Meter Support ..... 19

        3.3.9 Corrosion Protection ..... 19

        3.3.10 Thread Sealant..... 19

    3.4 METER SIZING\* ..... 19

    3.5 MANUFACTURED (MOBILE) HOME METER SET ASSEMBLY ..... 19

        3.5.1 Connection to house lines ..... 19

    3.6 HIGH PRESSURE SERVICE REGULATOR SETTINGS ..... 20

        3.6.1 Distribution Notification\* ..... 20

        3.6.2 Location..... 20

**PART 4 - INSPECTION, TESTING, AND PURGING ..... 21**

    4.1 INSPECTION AND TEST REQUIREMENTS ..... 21

        4.1.1 Customer charges ..... 21

        4.1.2 Notification for Testing..... 21

        4.1.3 Visual Inspection ..... 21

    4.2 NEW AND REPLACED SERVICE LINES ..... 21

        4.2.1 New Construction Pressure Test Requirements (2" and under)\* ..... 21

        4.2.2 Pressure test gases ..... 22

        4.2.3 Establishing gas service ..... 22

        4.2.4 Meter Installation ..... 22

**Standards for Customer Service Lines, Meters, and Service Regulators (Plumbers Guide)**

---

4.3 ABANDONED, TEMPORARILY DISCONNECTED, OR PARTIALLY REPLACED\* ..... 22

4.4 Reestablishing Gas Service\* ..... 23

    4.4.1 Leak detection ..... 23

4.5 PURGING PIPELINES\* ..... 23

    4.5.1 Purging with natural gas ..... 23

    4.5.2 Purging with air ..... 23

    4.5.3 Purge Points\* ..... 23

    4.5.4 Smell Check During Purging ..... 24

4.6 Record of results ..... 24

**APPENDICES**

APPENDIX A - Additional Explanatory Material

APPENDIX B - Meter Kind & Size, Capacity, and Dimensions

APPENDIX C - Pipe Sizing

APPENDIX D - Sketches

    Sketch No. 1 - Typical Service Line Locations

    Sketch No. 2 - Typical Service Line and Curb Valve Locations

    Sketch No. 3 - 2 inch Riser Piping Details

    Sketch No. 4 - Direct Burial Plastic Service Line

    Sketch No. 5 - Service Line Under Paved Area

    Sketch No. 6 - Entrance for Plastic Service Line

    Sketch No. 7 - Sleeves for Masonry Wall Entrances

    Sketch No. 8 - Prefabricated Masonry Wall Entrances

    Sketch No. 9 - Mobile Home Installations

    Sketch No. 10 - Remote Meter Set Details

    Sketch No. 11 - Tracer Wire Details

    Sketch No. 12 - Cased Steel Gas Line Laid Under Building

APPENDIX E - Forms

    Form 1 – C-3363, “Operator Qualification Card”

    Form 2 – C-3363, “Plumber’s Guide Revision Proposal”

**INDEX**

## **PART 1 - GENERAL**

### **1.1 SCOPE**

- (a) This manual, covering the installation, inspection, and testing of gas service lines, meter set assemblies, meters, and service regulators is published by Columbia Gas, herein referred to as the "Gas Company," for two purposes:
  - 1. As a compilation of standards in the industry for ready reference for those persons and firms doing work of the nature described herein; and
  - 2. To describe the inspection and testing of service lines which the Gas Company will require before establishing service.
- (b) The standards of this manual pertain to all customer service line installations which utilize plastic pipe sizes two inches and smaller. Consult the Gas Company for service line installations that use steel pipe or pipe sizes greater than two inches.
- (c) Consult the National Fuel Gas Code (ANSI 223.1, NFPA 54) for information covering the installation, inspection, and testing of house lines, appliances, and venting.
- (d) The provisions in this manual are subject to change and are not intended to be all-inclusive. Local codes, ordinances, and governmental regulations will govern when they are more stringent than the requirements contained herein. When in doubt as to the proper procedure, consult your Gas Company before proceeding with the work.
- (e) For other installation information:
  - 1. GPTC Guide for Gas Transmission and Distribution Piping Systems.
  - 2. Title 24, Code of Federal Regulations, Part 3280, Manufactured Home Standards.
  - 3. NFPA 501A Installation of Mobile Homes Including Mobile Home Park Requirements.
  - 4. Title 49, Code of Federal Regulations, Part 192 – Transportation of Natural Gas by Pipeline.
- (f) The Gas Company will not assume responsibility for any defective material or faulty workmanship in the installation or repair of the customer's house lines, appliances, appliance connections, appliance venting, or for any loss or damage arising from such defective material or faulty workmanship.

**PA:** The Gas Company will also not assume responsibility for any defective material or faulty workmanship in the installation or repair of the customer's service line or meter setting.
- (g) The nature and extent of the Gas Company's inspection and testing is set forth in Part IV, and nothing herein shall operate to enlarge or modify the Gas Company's responsibility for this inspection and testing.

### **1.2 CUSTOMER ADVISORY SERVICE**

- (a) To assist customers in obtaining maximum benefits at the lowest cost from the use of gas, the Gas Company maintains a staff of experienced personnel whose services are available.
- (b) The Gas Company will advise on gas applications, piping arrangements and furnish general information on the use and economics of natural gas for residential, commercial and industrial customers.
- (c) The Gas Company will provide advice and guidance to customers, plumbers, and other persons involved with the installation of customer service and house lines consistent with the following guidelines on sizing, materials, location, and installation. It is the ultimate responsibility of such customers, plumbers, and other persons to take the necessary action to make proper installations that are consistent with the objectives of the guidelines.

**Standards for Customer Service Lines, Meters, and Service Regulators (Plumbers Guide)**

---

- (d) The Gas Company will furnish information regarding local taxes, utilities, transportation, and the availability of labor supply on potential commercial and industrial sites.

**1.3 REQUEST FOR GAS SERVICE**

Request for service should be made by the customer or customer's representative. Information on how to make this request may be obtained from the Gas Company.

**1.3.1 Information Required**

The following information is needed when gas service is requested:

- (a) Name;
- (b) Exact address and description of the location at which service is requested;
- (c) Type of occupancy, such as residence (single or multiple), commercial, church, school, industrial, municipal, or other public use;
- (d) Contemplated use of gas, such as space heating, air conditioning, water heating, cooking, incineration, clothes drying, grilling, commercial and/or industrial processes;
- (e) Gas pressure required; and
- (f) Estimated date gas service will be required.

**1.3.2 Arrangements for Establishing Gas Service\***

- (a) The Gas Company will determine if a main extension is required, advise the customer or customer's representative of the terms and condition for the extension and explain deposit requirements, if necessary.
- (b) The customer or customer's representative will make arrangements for the installation, inspection, and testing of the customer service line in accordance with the standards and information set forth in this manual, and house lines in accordance with the National Fuel Gas Code.
- (c) Prior to calling for the Gas Company to establish service, builder/contractor will install the customer house line and:

**KY:** There must be at least one properly connected appliance.

**OH:** There must be at least one appliance drop with a plugged appliance valve. In addition, the following conditions must be met:

1. House line piping connecting to the meter setting shall:
  - a. be a minimum of Schedule 40 steel pipe,
  - b. be securely anchored inside the structure to support the piping and meter setting
  - c. be sealed to be rain and insect resistant,
  - d. terminate 2'-3' above finished grade (18" for 2" and over)
  - e. extend through the outside wall:
    - 4-6 inches for piping smaller than 2 inches,
    - 6-8 inches for piping 2 inches and larger for threaded connection, or
    - 10 inches for piping 2 inches and larger for welded connection.

**Standards for Customer Service Lines, Meters, and Service Regulators (Plumbers Guide)**

---

2. On multiple meter installations, each house line stub shall be identified with a tag of approved means to designate the apartment or the part of the building it supplies (see 3.3.3, 3.3.8, 3.5.1, 4.2.4, and A.1.3.2).
- (d) Call the Gas Company requesting visual inspection, pressure test, and meter installation after the following conditions have been met:
1. Service line, house lines, meter setting, and appliances, when applicable, are ready for inspections and tests.
  2. Where required, documentation of an Approval for Natural Gas Service from Building Code Officials.
  3. Access to all parts of the building with gas piping and/or appliances will be available to Gas Company personnel.
- PA:** Prior to calling for the Gas Company to establish service, the builder/contractor will install the customer service line and meter setting, and attach the appropriate Installation Card. The card attests that the person making the installation is qualified by "DOT Operator Qualification" (OQ Card, Form C-3363) when performing an OQ covered task.
- Gas Company personnel will test and inspect the customer service line to the meter setting. Based on the inspection, test, and Installation Card:
- a. gas service will be established to the meter valve if all are acceptable, or
  - b. the gas shall be left off at the curb valve if any are unacceptable.

**1.4 CUSTOMER CHARGES**

The first inspection and/or test (see PART 4 - INSPECTION, TESTING) shall be without charge. In the event the lines do not pass such inspection and/or test, or if other unsatisfactory conditions result in a disapproval, the necessary correction(s) shall be made at the owner's expense and the line involved shall again be inspected and tested. Additional inspection(s) and/or test(s) shall be subject to a charge.

**1.5 OWNERSHIP AND RESPONSIBILITY**

- (a) The materials, installation, and location of the customer service line and meter setting shall be subject to the standards contained herein.
- (b) The Gas Company retains ownership of the meter and service regulator(s). The Gas Company also retains ownership of the service line and meter setting.
- PA:** Certain locations, the customer retains ownership of the service line and meter setting.
- (c) The customer shall be responsible for house lines at their own expense.
- PA:** Certain locations, the customer shall also be responsible for:
1. The installation of new customer service line and meter setting(s),
  2. Relocation of the customer service line and meter setting at the customer's request,
  3. Customer service line and meter setting upgrades due to load changes,
  4. These lines and settings shall be subject to inspection and test as provided herein, but the Gas Company assumes no responsibility for their condition.
- (d) The Gas Company is responsible for the repair/replacement of hazardous leakage on service lines. Only the Gas Company or its agents are authorized to complete repairs and/or replacements.
- PA:** The customer shall also be responsible for the repair/replacement of hazardous leakage on customer-owned service lines.

**Standards for Customer Service Lines, Meters, and Service Regulators (Plumbers Guide)**

---

**1.6 DEFINITIONS**

**Abandoned** – A service line is classified as abandoned when it has been physically separated from the main and plugged or sealed.

**Accessible** – Availability in case of emergency, repair, or inspection may require the removal of a panel or door.

**Accessible, Readily** – Immediate availability in case of emergency, repair, or inspection.

**Anode** – The electrode of an electrochemical cell at which corrosion occurs. Required to protect a buried metallic pipeline from corrosion (see Cathodic Protection, 2.3.3, 2.3.5, and 2.6.4).

**Approved** – 1) Acceptable to the authority having jurisdiction. 2) See approved materials.

**Approved Materials** – Materials submitted for qualification and found to be satisfactory for the use intended will be added to the list of approved items. In addition, approved materials that do not continue to meet quality standards of the Gas Company will, after investigation, be deleted from the listing of approved items. Approved materials for the work described herein are listed by manufacturer's name and designation in the "Approved Materials for Customer Owned Service Lines" booklet that is available from the Gas Company. These listings are not arbitrarily maintained and are subject to revision by the Gas Company as the need arises. While it is the policy of the Gas Company to reissue these listings no more than once each calendar year, more frequent revisions may be issued if appropriate.

**Authority Having Jurisdiction** – Fire Chief, Local Code Official, Representative of the Gas Company, or others who are responsible for approving equipment, materials, installation, or procedures. Local codes, ordinances, and governmental regulations will govern when they are more stringent than the requirements contained herein. When in doubt as to the proper procedure, consult your Gas Company and other authorities before proceeding with the work.

**Cathodic Protection** – The prevention of corrosion of a pipeline by causing it to act as the cathode rather than as the anode (see anode) of an electrochemical cell.

**Corrosion** – The reaction of metallic pipeline to air, water, and other environmental factors causing the loss of metal and integrity. The most familiar example is rust.

**Customer** – the person, firm or corporation for whose account and use gas service is established and delivered.

**House Lines** – the piping and fittings from the outlet of the meter or the connection to the company service line if there is no meter set assembly, to the appliance shutoff valve.

**Main (line)** – distribution line that serves as a common source of supply for more than one service line.

**MAOP** (Maximum Allowable Operating Pressure) – Maximum pressure a pipeline or segment of a pipeline may be operated.

**Meter** – measures the transfer of gas from an operator to a customer.

**Meter Set Assembly** (Setting, Meter Setting) – the piping, fittings, meter valve, meter and when required the service regulator, installed to connect the customer service line to the house lines.

**Operator** – a "person" who engages in the transportation of gas.

**Operator Qualification Card** (Form C-3363) – documents qualification under federal regulations, required for installation, replacement or repair of service lines and/or meter settings.

**Plastic, High Density** – Black gas piping, tubing, and fittings conforming to ASTM D 2513 designations of PE3406, PE3408, or PE4710 (bimodal).

**Plastic, Medium Density** – Yellow, orange, or tan/pink (Aldyl A) gas piping, tubing, and fittings conforming to ASTM D 2513 designations of PE2306, PE2406, or PE2708.

**Standards for Customer Service Lines, Meters, and Service Regulators (Plumbers Guide)**

---

**Purging** is the process of displacing air with natural gas from a new or repaired pipeline OR displacing natural gas with air when repairing or abandoning a pipeline.

**Qualified** – capable of and skilled to perform a task based on appropriate training and/or experience.

**Regulator, High Pressure** – owned by the Gas Company and installed to reduce pressure to 99 psig or less so that it can be handled by a service regulator.

**Regulator, Service** – owned by the Gas Company and installed to reduce the service line gas pressure to house line delivery pressure.

**Retroactivity** – Unless otherwise stated, the provisions of this standard shall not be applied retroactively to existing system(s) that were in compliance with the provisions of the codes and standards in effect at the time of installation. Changes to the existing system(s) require installation in accordance with current codes and standards.

**Service Line** – a distribution line that transports gas from a common source of supply to an individual customer, to two adjacent or adjoining residential or small commercial customers, or to multiple residential or small commercial customers served through a meter header or manifold. A service line ends at the outlet of the customer meter or at the connection to a customer's piping, whichever is further downstream, or at the connection to customer piping if there is no meter.

**Service Line, Company** – the piping that extends from the Gas Company main to a curb valve or in the absence of a curb valve to the customer property line.

**Service Line, Customer** – the piping that extends from the end of the company service line at the property line to the inlet of the meter set assembly.

**Service Line Pressure, Low** – the pressure is substantially the same as delivered to the appliances, a service regulator is not required, normally 10" WC to 14" WC.

**Service Line Pressure, Intermediate** – above low pressure, requires a service regulator. Normally 2 psig to 10 psig but may drop to 1 psig during periods of full demand.

**Service Line Pressure, Medium** – higher than intermediate pressure, requires a service regulator. Normally 10 psig to 60 psig but may drop to 2 psig during periods of full demand.

**Service Line Pressure, High** – maximum allowable pressure exceeds 60 psig. High-density polyethylene plastic (HDPE – black PE-3408) may be installed to a maximum pressure of 99 psig.

**Shall** – Indicates a mandatory requirement.

**Valve, Curb\*** - [see A.2.5.3 (a)] a valve that, when required, isolates the customer and company service lines.

**Valve, Excess Flow\*** - [see A.2.5.3 (a)] a valve that, when required, reduces or stops the flow of gas when a rapid loss of pressure is detected in a gas line.

**Valve, House Line** – Gas shut off valve installed after the outlet of the meter usually before regulator at the manifold for elevated pressure house line piping.

**Valve, Meter** – Gas shut off valve installed before the regulator and meter, also called a Service Line Valve or Inlet Meter Valve.

**Valve, Outlet Meter** – Gas shut off valve installed after the outlet of the meter usually on the meter setting outlet.

## PART 2 - CUSTOMER SERVICE LINES

### 2.1 GENERAL REQUIREMENTS GOVERNING CUSTOMER SERVICE LINES

#### 2.1.1 One service line to one building.

Only one service line will be provided to single units, doubles (duplexes), apartments, condominiums, and strip units (see Sketch No. 1).

**Exception:** *Local code jurisdictions may require house lines to pass into or through only the unit served and therefore require separate service and/ or houses lines to each unit. Check local codes.*

#### 2.1.2 Existing Service Lines

Where a service line exists, a separate service line shall not be installed to a garage, workshop, or other building(s) on a single property.

#### 2.1.3 Property Lines

Customer service lines shall not cross or enter more than one customer property line.

#### 2.1.4 Split Service Lines

- (a) Customer service lines shall not be extended or split without Gas Company approval.
- (b) If approved, split customer service lines shall not serve more than two adjacent or adjoining meters and shall be entirely located on a single property.

#### 2.1.5 Service Classifications

- (a) A service line and premise status is classified as **New Service Line (NSL)** during the time interval between the service line installation and execution of the New Set Meter Order.
- (b) A service line, meter and premise status is classified as **inactive** when the meter valve and/or curb valve is **turned off and the meter is not removed** from the meter set assembly. A manifold setting must continue to have at least one inactive meter for the master service line (PSID) to be classified as inactive.
- (c) A service line and premise status is classified as **idle** when the meter of a single meter set assembly or the last remaining **meter** on a manifold setting **has been removed**.
- (d) A service line is classified as **abandoned** when it has been **physically separated from the main** and plugged or sealed.

### 2.2 LOCATION OF SERVICE

#### 2.2.1 Service line routing

- (a) In selecting the location of the service line, consideration shall be given to the best location for the connection to the main and the meter set assembly (see Sketch No. 2).
- (b) The service line should be installed in a continuous straight line perpendicular to the main to the point at which connection is made to the riser or where the piping enters the outer masonry wall of a building below grade (see Sketch No. 2). A short 90° offset at the side(s) of the building nearest the mainline may be permitted.

#### 2.2.2 Service entrance

The service line should enter the building wall above grade.

**Standards for Customer Service Lines, Meters, and Service Regulators (Plumbers Guide)**

---

- (a) **Above grade** - Where the customer service line is to enter through the outer wall of the building above grade, a flexible steel casing or rigid steel encased non-corrosive riser shall be used so that the transition from plastic to steel may be above ground (see Sketch No. 6).
- (b) **Below grade**
1. When a plastic service line enters through the outer wall of the building below grade it shall be encased with steel pipe through the foundation wall and the transition from plastic to steel shall be made inside using an approved adapter fitting as used for insert renewal of service lines (see 3.2.1(e) and Sketches 5-8 & 12).
  2. As an alternate below ground service entrance, a rigid, straight, prefabricated non-corrosive type cased gas line may be used as a combination casing and transition fitting. The rigid portion is fixed in the wall so that the plastic to steel transition (or ground level marking) is through the wall on the basement side (see Sketch No. 6).
- (c) **Masonry wall** - A service line installed through the outer masonry wall of a building, either above or below grade, shall be encased in a sealed and approved steel or plastic sleeve.
1. Galvanized steel sleeves are not permitted below grade.
  2. The opening between the sleeve and the outer masonry wall shall be filled with grout or sealed by the use of service entry flanges (see Sketch No. 7 & Sketch No. 8).

**2.2.3 Installation of service lines under buildings\***

- (a) Service lines should not be installed under buildings unless it is unavoidable.
- (b) Where an underground service line is installed under a building:
1. It shall be encased in a gas tight conduit capable of withstanding any superimposed stresses, required pressure test, protected from corrosion; and
  2. The conduit and the service line shall, if the service line supplies the building it underlies, extend into a normally usable and accessible part of the building; and
  3. The space between the conduit and the service line shall be sealed to prevent gas leakage into the building. If the conduit is sealed at both ends, a vent line from the annular space must extend to a point where gas would not be a hazard, and extend above grade, terminating in a rain and insect resistant fitting (see Sketch No. 12).
  4. An existing steel line shall pass a test at operating pressure for three minutes to ensure it is gas tight prior to use as the conduit.
  5. Metal conduit and/or piping must be protected from corrosion.

**2.3 MATERIALS**

Only materials approved by the Gas Company shall be used. A list of approved materials is found in the Gas Company listing entitled "Materials for Customer Service Lines" available on the internet at <http://www.columbiagasohio.com/> for Ohio or <http://www.columbiagasamd.com/> for Pennsylvania and Maryland.

**2.3.1 Plastic Pipe and Tubing**

- (a) Plastic pipe and tubing shall conform to ASTM D 2513, Specifications for Thermoplastic Gas Pressure Pipe, Tubing, and Fittings.
- (b) Medium density plastic pipe and fittings shall not be used to repair high density plastic service lines.
- (c) A list of approved manufacturers of pipe is found in the Gas Company listing entitled "Materials for Customer Service Lines."

**Standards for Customer Service Lines, Meters, and Service Regulators (Plumbers Guide)**

---

**2.3.2 Steel Service Pipe\***

Where steel pipe is to be used for installing underground customer service lines, consult the Gas Company for material and installation requirements. Steel customer service line installations shall not be approved unless designated for steel by the Gas Company Engineering Department. All welding shall be done by a qualified person (see A.2.3.2).

**2.3.3 Mechanical Fittings\***

(a) Mechanical fittings must be approved and installed in accordance with manufacturer's installation instructions. A list of Gas Company approved fittings is found in the "Materials for Customer Service Lines."

(b) Metal fittings underground shall be cathodically protected and coated and/or wrapped.

**Note:** *To provide cathodic protection, isolated metal fittings underground shall have an anode (1 lb. minimum) attached. Metal fittings underground attached to metal piping shall have an anode (3 lb. minimum) attached [see 2.6.4 and 4.1.3(d)].*

**2.3.4 Plastic Fusion Fittings\***

Approved plastic pipe fittings designed for making heat fusion joints may be used to connect lengths of plastic pipe. Consult the Gas Company before joining dissimilar materials. Plastic pipe fittings shall conform to ASTM D 2513 and 2683. Persons making fusion joints shall have a valid "Fusion Qualification Card" from an approved agency.

**2.3.5 Screw Fittings**

(a) Screw fittings shall be used above ground only and shall be black or galvanized malleable iron, standard weight of banded type. Unions are permitted, only above ground, when required.

**Exception:** *A "mechanical/adaptor fitting", specifically designed and approved to mechanically join plastic pipe to a screw end curb valve, may be used underground but shall be coated and/or wrapped and cathodically protected. Metal fittings underground attached to metal piping shall have an anode (3 lb. minimum) attached.*

**Note:** *Screw fittings shall comply with the requirements of ANSI B16.3—American Standard for Malleable Iron Screwed Fittings and ANSI B2.1—American National Standard for Pipe Threads (except dryseal).*

(b) All thread nipples, and cast iron fittings shall not be permitted.

(c) Threaded joints shall have sealant approved for natural gas applied according to the manufacturer's instructions.

**2.3.6 Risers**

(a) **Outside riser, outside meter** - An approved flexible steel casing or rigid non-corrosive steel encased plastic service line riser shall be used with plastic service lines (see Sketch No. 3 & Sketch No. 4). A wall mounting plate or bracket fastened to the riser and building wall shall be used to firm the installation. Where it is not practical to attach the bracket to the building wall, a heavy gauge steel stake, or equivalent, firmly embedded parallel and immediately adjacent to the foundation wall shall be used as a support (see Sketch No. 9 & Sketch No. 10).

(b) **Risers in Concrete or Asphalt** - Where a riser passes through a walk, patio, or driveway, it shall be installed through a sleeve or other means of providing a space between the riser and the walk, patio, or driveway. The space between the sleeve and riser shall be filled with gravel (see Sketch No. 5).

**Standards for Customer Service Lines, Meters, and Service Regulators (Plumbers Guide)**

---

**2.3.7 Meter Valves**

Meter valves approved by the Gas Company shall be used.

- (a) Valves, nominal pipe sizes  $\frac{3}{4}$ , 1, and 1- $\frac{1}{4}$  inches, shall be of the insulating union-type, having lock wing head or equivalent, and tamperproof core. These meter valves shall be provided with a drilled and tapped 1/8-inch port on the inlet side of the valve body for test purposes. An Allen head plug shall be used to close the port.
- (b) Where the inlet piping to a single meter set assembly is 2 inches nominal pipe size or greater, an insulating union, flange or coupling shall be installed in the setting above ground and downstream of the meter valve. The insulator is preferred downstream of the regulator (if one exists) to electrically isolate the service line from the house lines. In addition, a test tee shall be installed above ground upstream of the meter valve (see Sketch No. 3).

**2.4 SERVICE LINE SIZING\***

Refer to APPENDIX C - Pipe Sizing.

In determining the size of service lines to be used in designing a gas piping system, ALL SIX of the items of this section (2.4.1 – 2.4.6) shall be considered.

**2.4.1 Pipe Material**

Plastic pipe sizing tables are in Appendix C. Contact the Gas Company for information on the use of steel pipe.

**2.4.2 Available Service Line Pressure**

- (a) **Low Pressure Service Lines** - Low pressure customer service lines shall not be less than 1 inch CTS. The line shall be sized according to **Appendix C, Table 1**.
- (b) **Intermediate Pressure Service Lines** - Intermediate pressure customer service lines shall not be less than 3/4 inch CTS when installed on systems to operate at 1 psig minimum pressure. The line shall be sized according to **Appendix C, Table 2**.

**Exception:** *On piping systems specifically designated by the Gas Company Engineering Department to operate at 2 psig minimum pressure, 1/2" CTS (5/8) may be used (Table 3).*

- (c) **Medium Pressure Service Line** - Medium pressure customer service lines shall not be less than 1/2 inch CTS. The line shall be sized according to **Appendix C, Table 3**.
- (d) **High Pressure Service Lines** - High-density polyethylene plastic (HDPE – black PE-3408) may be installed to a maximum pressure of 99 psig. The line shall be sized according to **Appendix C, Table 4**. Consult the Gas Company for sizing, material information, and installation practices for all other high-pressure service lines.

**2.4.3 Pressure Drop**

Contact the Gas Company for allowable pressure drops from the main to the meter other than specified by the applicable table in Appendix C.

**2.4.4 Specific gravity and Heating Value of the gas**

Columbia distributes **Natural Gas** with approximately: Specific Gravity of **0.6** and a Heating Value of **1000 Btu/cubic foot**.

**2.4.5 Length of Piping**

In sizing the customer service line, the entire service line (company service plus the customer service line) shall be treated as a unit.

**Standards for Customer Service Lines, Meters, and Service Regulators (Plumbers Guide)**

---

**2.4.6 Determining the Load**

Gas demand in cubic feet per hour is determined by:

- (a) **Residential** – input of space and water heating equipment. When the input rate of other appliance(s) such as a pool heater or air conditioner is more than the furnace, the total of the greater should be used. In the absence of central heating equipment, load requirements shall be determined from the total input requirements for all appliances.
- (b) **Commercial** – input of all connected appliances.
- (c) **Diversity Factor** – ratio of the maximum probable demand to the maximum possible demand.

**2.5 INSTALLATION****2.5.1 General**

- (a) The maximum allowable operating pressure of plastic pipe for service lines is limited to: 60 psig for medium-density (yellow PE-2406), and 99 psig for high-density (black PE-3408).
- (b) Plastic pipe above grade is prohibited except that which may terminate aboveground in an approved riser or installed with an approved wall head adapter in the basement.
- (c) The Gas Company shall inspect the customer service line before backfilling any excavation(s), in accordance with the requirements in PART 4 - INSPECTION, TESTING of this manual.
- (d) Solvents, pipe thread compound and lubricants, except those specifically deemed safe for use with plastic materials, shall not be allowed to contact the plastic. Consult manufacturers' recommendations.
- (e) Plastic pipe shall not be installed in vaults or other below grade enclosures, unless it is completely encased in a gas tight metal conduit and metal fittings having adequate corrosion protection.
- (f) Plastic pipe shall not be damaged. Gouges, grooves, kinks, and/or buckles shall be removed by cutting the damaged portion as a cylinder. Plastic pipe with wall thickness damage of 10% or greater shall not be used.
- (g) Plastic pipe shall be protected from fire and heat. Exposure to sunlight shall be minimized. Plastic pipe that has been exposed to excessive sunlight will discolor and show craze marks and shall not be used.
- (h) Plastic pipe older than 24 months shall not be used unless approved by the Gas Company after proper testing by a qualified agency and found acceptable within 90 days of the installation.
- (i) Plastic pipe shall be installed to minimized shear and tensile stresses from construction, back fill, and external loading. It shall be laid on undisturbed or well-compacted soil and may not be supported by blocking.
- (j) Plastic pipe shall be provided sufficient slack for thermal expansion and contraction.

**2.5.2 Trenching**

- (a) A plastic service line shall be laid on undisturbed or well-compacted soil not less than 6" from any other underground structure.
- (b) Plastic service lines shall be laid at sufficient depth to provide a minimum of 18 inches of cover over the pipe.
- (c) When the service line is in a trench with other utility services a minimum separation of 12 inches horizontally shall be provided.
- (d) There shall be at least six inches of clearance where it is necessary for other utility services to cross either over or under the service line. Where possible, there should be a minimum one-foot separation with all electric carrier conductors.

**Standards for Customer Service Lines, Meters, and Service Regulators (Plumbers Guide)**

(e) It shall not be run through septic tanks and/or leaching beds.

**2.5.3 Joining Pipe\***

- (a) It is preferable to install the plastic service line as one continuous length of pipe between the curb valve and/or excess flow valve at the property line and the riser or joint of connection to coated steel pipe at the building.
- (b) Where it is necessary to use more than one length of plastic pipe in the customer service line, the lengths shall be joined by either an approved mechanical fitting or heat fusion joint. When a mechanical fitting is used it must be installed in accordance with the manufacturer's installation instructions.
- (c) When there is an existing curb valve, connections shall be made by a DOT Operator Qualified person(s) installing the service line.
- (d) When the service line is installed prior to the main line tap installation, the Gas Company personnel will test and connect the service line if:
  - 1. the meter setting and service line are ready for inspection and test, and
  - 2. the Operator Qualification Card (Form C-3363) is attached to the meter setting.
- (e) Metal fittings underground shall be cathodically protected and coated and/or wrapped.
- (f) The procedure and equipment recommended by the manufacturer of the approved plastic pipe for making heat-fusion joints shall be used. Socket fused plastic fittings may be used on approved sizes up to, but not including 2 inches. When fusing sizes 2 inches and larger, butt fusion and electro-fusion are permitted.
- (g) Direct application of heat with a torch or other open flame to the plastic pipe is prohibited.
- (h) Persons making plastic pipe joints must be qualified to make that type of joint. As proof of qualification, the person making any joint on plastic pipe must complete and attach to the meter setting an Operator Qualification Card (Form C-3363). The Gas Company representative can supply information on obtaining qualification, the applicable cards, and the procedures to follow on the job. This information is also available on the internet at <http://www.columbiagasohio.com/> for Ohio or <http://www.columbiagasohio.com/> for Pennsylvania and Maryland.

**Note:** *Joints in service lines not exposed for visual inspection or without a completed Operator Qualification Card shall not be approved.*

**2.5.4 Bends**

Changes in direction of plastic piping may be made with bends or elbows under the following limitations:

- (a) Follow the pipe manufacturer's recommendation for the minimum bending radii. The following minimum bending radii will satisfy most recommendations.

**Minimum Bending Radii (R)**

<b><u>Size</u></b>	<b><u>125 x OD*</u></b>	<b><u>25 x OD**</u></b>
½" CTS	7'	1.5'
1" CTS	12'	2.5'
1 ¼ IPS	18'	3.5'
2" IPS	25'	5.0'

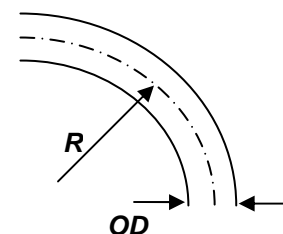

\*125 x OD = outside diameter for service lines **containing** fusion joints (butt, socket, and saddle) or fittings within the bend radius.

**Standards for Customer Service Lines, Meters, and Service Regulators (Plumbers Guide)**

---

\*\*25 x OD = outside diameter for service lines **without** fusion joints or fittings within the bend radius.

- (b) The bends shall be free of damage.
- (c) Changes in direction that cannot be made in accordance with (a) above shall be made with elbow type fittings.

**2.5.5 Tracer Wire**

- (a) A Gas Company-approved tracer wire shall be installed with all non-cased plastic service lines to facilitate pipe locating. For direct burial installations, the tracer wire shall be a minimum AWG #14 and should have a yellow jacket. For trenchless technology installations (boring), the tracer wire should be a minimum AWG #12 for reinforced copper-cladded wire, and a minimum AWG #8 for solid copper wire.

**Exception:** *In PA/MD, the minimum tracer wire size is AWG #12 and it shall have a yellow jacket.*

- (b) The wire shall be accessible so connection can be made to the locator transmitter (see Sketch No. 11) by bringing the wire up along the outside of the curb box and riser.
- (c) The wire shall not be wrapped around the pipe and contact with the pipe should be minimized.

**Note:** *When inserting a plastic service line through an old steel service line attach the wire at the cut section(s) of remaining steel pipe before inserting the plastic.*

**2.5.6 Backfilling**

- (a) The Gas Company shall visually inspect the customer service line before backfilling any excavation(s) in accordance with the requirements in PART 4 - INSPECTION, TESTING of this manual.
- (b) Backfilling shall be performed in a manner to provide firm support around the piping.
- (c) The backfill shall be free of large rocks, building materials, etc. that might cause damage to the plastic pipe. Small-excavated rocks may be returned to the trench, but shall be prevented from contacting the pipe by earth padding of not less than six (6) inches above the pipe.
- (d) No heavy equipment shall be run over the customer service line or trench immediately after it has been back filled.
- (e) Where flooding of trench is done to consolidate the backfill, care shall be taken to see that the plastic pipe is not floated from its firm bearing on the bottom of the trench.

**2.6 INSERT RENEWAL OF EXISTING CUSTOMER SERVICE LINES**

Additional requirements for insert renewal of existing customer service lines.

**2.6.1 Material**

Only materials approved by the Gas Company shall be used in the plastic relining of the customer service line.

**2.6.2 Sizing**

- (a) The size of the plastic piping used as an insert to renew customer service lines shall be based on Appendix C Sizing Tables No. 1, 2, 3, or 4.
- (b) Plastic pipe of 1/2 inch CTS (5/8 inch OD) size may only be inserted into existing 3/4 inch or 1 inch IPS service lines that operate at greater than 10 psig pressure (see exception below).
- (c) The insertion of 1/2 inch CTS through 1 1/4 inch or larger pipe is discouraged because of the possibility of water in the casing freezing and squeezing-off the plastic pipe.

**Standards for Customer Service Lines, Meters, and Service Regulators (Plumbers Guide)**

---

**Exception:** *On piping systems specifically designated by the Gas Company Engineering Department to operate at 2 psig minimum pressure, 1/2 inch CTS (5/8 inch OD) may be used (Appendix C, Table 3).*

**2.6.3 Installation**

- (a) The casing pipe shall be reamed and cleaned to the extent necessary to remove any sharp edges, projections, or abrasive material that could damage the plastic during or after insertion.
- (b) Plastic pipe shall not be inserted in an old service line (casing) that does not have at least 12 inches of cover in private property and at least 18 inches of cover in streets and roads.
- (c) The plastic shall be inserted into the casing pipe in such manner so as to protect the plastic during the installation. The leading end of the plastic shall be closed before insertion. Care shall be taken to prevent the plastic from bearing on the end of the casing.
- (d) That portion of the plastic service line piping not encased shall be continuously supported to prevent shearing and a plastic pipe shim shall be installed where it enters and leaves the casing.
- (e) The end of the casing pipe nearest curb stop shall be sealed or taped to prevent migrating gas from entering the structure.
- (f) In cases where the meter is located in the basement and the service line enters the wall below grade, the plastic insert shall be connected to the meter riser using an adapter fitting for plastic insert renewal. (See Sketch No. 6.)
  - 1. The steel casing pipe entering through the wall may be used as the required sleeving provided that it is good condition and firmly anchored in the wall. The opening between the casing pipe and wall shall be filled with grout or sealed by the use of a service entry flange (See Sketch No. 7).
  - 2. Exposure of plastic within the building being served is prohibited.
  - 3. The steel casing pipe shall be exposed, cut, and sealed at 12 inches beyond the exterior wall (See Sketches 5 & 6). It shall be sealed to prevent migrating gas from entering the structure and be vented when installed under pavement.
- (g) In cases where the meter set assembly or riser is located outside of the building being served, the riser shall be replaced with a flexible steel casing type or rigid non-corrosive steel encased type (see 2.3.6).
- (h) When plastic pipe is inserted through an old steel service line tracer wire shall be attached at the cut section(s) of remaining pipe to maintain electrical continuity

**2.6.4 Anode Installation.**

- (a) To provide cathodic protection isolated underground metallic fittings with plastic pipe underground shall have an anode (1 lb. minimum) attached.
- (b) Underground metallic fittings attached to metal piping and/or fittings shall have an anode (3 lb. minimum) attached.
- (c) When practical the anode lead wire should be tied around the pipe prior to attachment to prevent pullout.
- (d) The anode shall be placed so the lead wire is never lower than the rest of the anode. The anode lead wire shall be attached at or near the top of the pipe or fitting.
- (e) The preferred attachment is a thermit weld, but fitting crimp connections are acceptable when provided. Approved clamp connections are permitted when the fitting does not have a crimp connection.
- (f) The anode shall be deeper in the ground than the pipeline.

**Standards for Customer Service Lines, Meters, and Service Regulators (Plumbers Guide)**

---

- (g) Separation between the pipe and magnesium anodes may be reduced to 2 feet. Separation between the pipe and 1 lb. zinc anodes may be reduced to 1 foot.

## **PART 3 - METER SETTINGS**

### **3.1 GENERAL**

#### **3.1.1 Meter**

- (a) The Gas Company will furnish and connect a meter for each customer.
- (b) The Gas Company reserves the right to determine the size and type of meter to be installed.
- (c) The meter remains the property of the Gas Company.

#### **3.1.2 Meter Valves and/or Bars**

Meter valves (see 2.3.7) and when applicable, meter bars shall be approved by the Gas Company.

#### **3.1.3 Meter Settings**

- (a) When applicable, only prefabricated meter setting assemblies approved by the Gas Company shall be used.
- (b) When applicable, Gas Company meter setting "standard drawings" (e.g., Plumber's Drawings) shall be followed. Written permission is required for deviation from the standard drawings.

#### **3.1.4 Service Regulators\***

- (a) When service is provided from distribution mains at pressures in excess of 1 psig, a proper service regulator, approved by the Gas Company, shall be used. A proper service regulator is one that can reduce the pressure to that required by the house piping system or to that recommended for household appliances.
- (b) The service regulator(s) shall remain the property of the Gas Company.
- (c) A single service regulator shall not serve more than eight (8) meters without Gas Company approval.

#### **3.1.5 Regulator Relief Vent\***

- (a) Each service regulator that incorporates a relief device and is installed inside a building shall have a separate relief line vented outdoors to a safe location not less than three (3) lateral feet from sources of ignition or openings into buildings (see A.3.1.5 and A.3.3.2.).
  - 1. If pipe is used for the vent line, the pipe shall be metallic and at least as large as the regulator vent opening.
  - 2. If tubing is used for the vent line, the tubing shall be metallic and one size larger than the vent opening. Corrugated tubing shall not be used for regulator vents.
  - 3. The outside terminal of each service regulator vent must be:
    - i. rain and insect resistant, and
    - ii. located at a place where gas from the vent can escape freely into the outside atmosphere to a safe location away from any opening into the building, and
    - iii. elevated to prevent submergence in areas where flooding may occur, and
    - iv. protected from damage.
  - 4. Relief vent lines should be as short as practical, and when over 10' in length or contain more than two (2) elbows, should be increased one nominal pipe size for each 10' of length. Each elbow in the vent line will contribute about three (3) feet to the effective length.

**Standards for Customer Service Lines, Meters, and Service Regulators (Plumbers Guide)**

---

- (b) Service regulators installed outdoors of a building may use PVC plastic as the vent line, conforming to UL 651, Schedule 40 or Schedule 80 rigid PVC conduit. PVC vent piping shall not be installed indoors.

**3.1.6 Establishing gas service**

In no case shall a customer, his agent, or employee:

- (a) Establish the initial gas service to a customer.
- (b) Turn on the gas at the curb valve.
- (c) Turn on the gas at the meter inlet valve.
- (d) Reconnect the meter inlet or outlet when disconnected by an employee or agent of the Gas Company.

**3.1.7 Interruption of service**

When it is necessary to make house line piping repairs or alterations, and:

1. an outlet meter valve exists, a qualified pipe fitter or plumber may turn off the gas, complete the work in accordance with all applicable codes and standards, then re-establish the gas service; or
2. an outlet meter valve does not exist, then contact the Gas Company for inspection and testing.

**EXCEPTION:** *In OH, the Gas Company shall always be contacted to perform a leak test of the downstream piping and re-establish service.*

**3.2 METER SETTING LOCATION\*****3.2.1 General**

- (a) The Gas Company reserves the right to determine the location of the meter set assembly.
- (b) New meter settings are to be located outside, except for a dedicated meter setting building, unless it is unavoidable and a representative of the Gas Company gives prior approval. New meter settings installed inside of a non-dedicated meter setting building shall comply with 3.2.1(c).
- (c) Existing meter settings located inside should be moved outside at the time of service line repair or replacement.
  1. Meters remaining inside shall be in a well-ventilated space and not less than three (3) feet from any source of ignition or any source of heat which might damage the meter.
  2. Settings remaining inside shall comply with 3.2.1(d) or (e) as applicable.
  3. Settings remaining inside shall be located as near as practical to the riser or the point where the service line enters the building.
- (d) Inside Meter Setting, Entrance Above Grade. Where the service line enters the structure above grade when the meter is to be located in the basement or on the ground floor level in a garage, utility room, or room approved for the meter location, an approved riser shall be installed in accordance with the requirements of 2.3.6(a) (see Sketch 6).
- (e) Inside Meter Setting, Entrance Below Grade. Where the meter is to be located inside the basement of a building and the service line enters the structure below grade:
  1. the inside piping should be installed to allow sufficient height for the meter set assembly, and
  2. the wall head adapter shall be installed approximately six inches from the wall, and
  3. all inside service line piping shall be exposed and accessible (see Sketch 6), and
  4. underground metallic piping shall be coated and/or wrapped and have an anode installed, and

**Standards for Customer Service Lines, Meters, and Service Regulators (Plumbers Guide)**

---

5. where the conduit passes through a wall it shall be encased in a sealed and approved steel or plastic sleeve or grout (see Sketches 5, 6, 7 & 8), and
  6. the conduit shall:
    - (a) extend one foot outside the building line, and
    - (b) be sealed at the foundation wall to prevent leakage into the building, and
    - (c) terminate at a point inside the building that is accessible for service and inspection, and
    - (d) when under solid surfaces for more than 8' from the point of entry the conduit shall be vented above grade to outside and be installed so as to prevent the entrance of water and insects (see Sketch 5 & 12).
  7. In the case of plastic service line, be protected from shearing action and backfill settlement.
- (f) When a service line is installed under a building:
1. the service line piping shall be encased in a gas tight conduit designed to withstand the superimposed loads, and
  2. the space between the service line and conduit shall be sealed to prevent the possible entrance of any gas into the building, and
  3. service line and conduit shall terminate at a point inside the building that is accessible for service and inspection, and
  4. if the conduit is sealed at both ends, a vent line from the annular space must extend to a point where gas would not be a hazard, and extend above grade, terminating in a rain and insect resistant fitting.
- (g) Meter settings should be perpendicular to the connection to the company service line (see Sketch 1). A short 90° off set at the side(s) of the building nearest the mainline may be permitted.

**3.2.2 Meter Setting Accessibility**

The meter set assembly shall be readily accessible for examination, reading, repair, and replacement.

**3.2.3 Piping Accessibility**

All piping, from the service line riser or point where the service line enters the building to the location of the meter set assembly, shall be exposed and accessible.

**3.2.4 Ventilated Area**

The meter set assembly shall not be installed in a small, unventilated, or confined space.

**3.2.5 Protected from Damage**

The meter set assembly shall not be placed where it will be exposed to damage such as in driveways, parking lots, public passages, halls, coal bins, etc., or where it will be subjected to excessive corrosion or under fire escapes.

***Note:** Where deemed necessary by the Gas Company the customer shall provide suitable protection for the meter setting. The type of protection to be used shall be under the direction of the Gas Company.*

**3.2.6 Protect from Heat/Ignition\***

The meter set assembly shall be located in a readily accessible, ventilated area at a minimum distance of **three feet (914mm) from** any source of ignition or any source of heat that might damage the meter.

**Standards for Customer Service Lines, Meters, and Service Regulators (Plumbers Guide)**

---

Locations at which there are either extreme temperatures or sudden changes in temperatures should be avoided.

**3.2.7 Regulator Location**

- (a) Regulators shall be located at a place where gas from the vent can escape freely into the outside atmosphere to a safe location away from any opening into the building.
- (b) High-pressure regulators shall be installed outside of the building being served.
- (c) Service regulators should be installed outside of the building where practical.

**3.3 INSTALLATION****3.3.1 Meter Valve**

A meter valve approved by the Gas Company shall be installed in the service line upstream of the meter and/or service regulator inlet (see 2.3.7).

**3.3.2 Master Meter Valve**

- (a) When gas is supplied from a Low Pressure system to six or more meters on a manifold, a master valve controlling the gas supply to all meters must be provided in addition to the meter valves controlling the supply to each meter.
- (b) Where a regulator is to supply two or more meter set assemblies, there shall be a master valve controlling the gas supply on the inlet side of the regulator in addition to the valves controlling the gas supply to each meter.
- (c) Where manifold branches each require separate regulators, there shall be a valve controlling each regulator and there shall be a master valve controlling the gas supply to all regulators in addition to the valves controlling the gas supply to each meter.

*Note: The master valve does not have to be of the insulating type. Manifolds shall be insulated in accordance with paragraph 3.3.7.*

**3.3.3 Meter Tags**

On multiple meter installations, each meter valve or house line shall be plainly and properly identified by the installing agent with a weatherproof tag or other approved means of designating the apartment or the part of the building it supplies.

**3.3.4 Manifold Piping**

- (a) Manifolds should not be more than two tiers high.
- (b) A single regulator should not serve more than eight (8) meters.
- (c) Distance from the riser to the top of the header piping should not exceed six (6) feet.
- (d) Valves are required for the header, for each regulator, and for each meter.
- (e) Manifolds shall be as close as practicable to header piping.
- (f) Normally, piping making up an outside manifold meter set assembly shall be located above ground. However, if all joints to the manifold header are made by welding and the manifold header and risers are coated with an approved material and protected by a magnesium anode, this piping may be located underground.

**3.3.5 Meter Clearance**

Distance between meter and any obstruction to the sides, rear, top, or bottom shall be minimum of six (6) inches. Distance between the meter and any obstruction from the front shall be a minimum of thirty

**Standards for Customer Service Lines, Meters, and Service Regulators (Plumbers Guide)**

---

(30) inches. On outside meter settings, the bottom of the meter shall be a minimum of six (6) inches above finished grade.

**3.3.6 Plumb and Level**

Meter set assemblies shall be plumb and level so that the meter will line up properly with the meter connections.

**3.3.7 Electrical Isolation, Grounding, and Bonding**

- (a) Gas piping shall not be used as a grounding conductor.
- (b) An insulator shall be installed in the meter setting to electrically isolate the service line from the house line. Insulation is normally provided through the use of insulated meter valves but insulated bars, swivels, unions, couplings, or flanges may be required in some instances.
- (c) House line bonding wires shall not be connected to meter settings, meter manifolds, or service lines. The house line bonding wire shall be connected to the ground in the electrical breaker box or the building electrical ground rod, and at a house line fitting or pipe as close to the electric panel as practical. Connecting in a close proximity to the gas meter is also desirable.

**3.3.8 Meter Support**

To minimize stress on the piping and meter, the meter setting must be properly supported, by rigidly supporting the riser and rigid support either provided by the house line connection or alternative means if no house line initially exists.

For remote settings (cannot be attached to foundation bracket), refer to Sketch 10 in Appendix D.

**3.3.9 Corrosion Protection**

- (a) Above ground metallic pipelines outside that are exposed to atmosphere shall be cleaned and either coated or painted with a suitable material to prevent corrosion.
- (b) Under ground metallic pipelines shall be coated and/or wrapped and cathodically protected.

**3.3.10 Thread Sealant**

Where threaded connections are made on the aboveground piping, a sealant approved for natural gas shall be applied according to the manufacturer's instructions.

**3.4 METER SIZING\***

Meter sizing is based on gas demand in cubic feet per hour (load).

1. **Residential** – input of space and water heating equipment. When the input rate of other appliance(s) such as a pool heater or air conditioner is more than the furnace the total of the greater should be used. In the absence of central heating equipment, load requirements shall be determined from the total input requirements for all appliances.
2. **Commercial** – input of all connected appliances.
3. **Diversity Factor** – ratio of the maximum probable demand to the maximum possible demand.

**3.5 MANUFACTURED (MOBILE) HOME METER SET ASSEMBLY****3.5.1 Connection to house lines**

See Sketch No. 9.

- (a) The meter setting shall be rigidly supported at both the riser and on the house lines.

**Standards for Customer Service Lines, Meters, and Service Regulators (Plumbers Guide)**

---

- (b) An approved manufactured (mobile) home connector shall connect the meter setting to the house lines.
- (c) The manufactured (mobile) home connector shall be listed, and:
  - 1. installed in accordance with manufacturer's instructions, and
  - 2. shall not be less than ¾-inch I.D. tubing size, and
  - 3. shall not be more than 40 inches in length.

**3.6 HIGH PRESSURE SERVICE REGULATOR SETTINGS****3.6.1 Distribution Notification\***

When service is provided from a high pressure line not part of the distribution system from which customers are normally supplied, the Gas Company's Distribution Service Department shall be consulted for customer service line requirements and specifications.

**3.6.2 Location**

High-pressure regulators SHALL be located outside the building being served.

## **PART 4 - INSPECTION, TESTING, AND PURGING**

### **4.1 INSPECTION AND TEST REQUIREMENTS**

Requirements for customer owned service lines and meter setting installations.

#### **4.1.1 Customer charges**

The first inspection and/or test shall be without charge. In the event the lines will not pass such inspection and test or if other unsatisfactory conditions result in the disapproval, the necessary correction(s) shall be made at the owner's expense and the line involved shall again be inspected and tested. Additional inspection(s) and/or test(s) shall be subject to a charge.

#### **4.1.2 Notification for Testing**

- (a) The customer or customer's representative will make arrangements for the installation, inspection and testing of the customer service line in accordance with the standards and information set forth in this manual and house lines in accordance with the National Fuel Gas Code.
- (b) Call the Gas Company, in advance of the time when desired, requesting visual inspection, pressure test, and meter installation after the following conditions have been met:
  1. Service line, house lines, meter setting, and appliances, when applicable, are ready for inspections and tests.
  2. Where required, a plumbing release for new construction and certificate of occupancy.
  3. Gas Company personnel shall have access to all parts of the building with gas piping and/or appliances.

#### **4.1.3 Visual Inspection**

- (a) The Gas Company shall visually inspect the customer service line before backfilling any excavation(s) made during plastic insert renewal work, boring, or vibra-plow installation of piping.
- (b) A plastic service line installed in a trench may be back filled for protection; however, the end connections and all fittings shall remain exposed for visual inspection.
- (c) Steel service lines shall be visually inspected before back filling any excavation(s).
- (d) Isolated metal fittings underground shall be visually inspected for a properly sized attached anode prior to being coated and/or wrapped. They shall be coated and/or wrapped prior to backfill. An additional trip to visually inspect coating and/or wrapping is not required.

### **4.2 NEW AND REPLACED SERVICE LINES**

Additional requirements for new and replaced customer-owned service lines and meter setting installations.

#### **4.2.1 New Construction Pressure Test Requirements (2" and under)\***

A new customer service line shall be given a pressure test after construction and before being placed in service to demonstrate that it is gas tight. Service lines shall be pressure tested at **1.5 x MAOP or 90 psig**, whichever is greater, for at least **5 minutes** with **no drop** in pressure, and a leakage check shall be made at operating pressure of all exposed fittings in the service line that were not included in the pressure test.

***Note:** For service lines to operate at pressures above 99 psig, consult the Gas Company.*

**Standards for Customer Service Lines, Meters, and Service Regulators (Plumbers Guide)**

---

**4.2.2 Pressure test gases**

Air, nitrogen, carbon dioxide, or other inert gas shall be used to pressurize gas lines for testing. See Section **Error! Reference source not found.** for gases that shall not be used.

**4.2.3 Establishing gas service**

A representative of the Gas Company shall establish gas service after passing the required inspection and test. In no case shall a customer or his agent or employee turn on the gas at the curb valve, meter valve, or reconnect the meter inlet or outlet.

**4.2.4 Meter Installation**

A gas meter may be set and the gas turned on if the service line, meter setting, and installed house lines pass required inspection and testing.

(a) The meter setting shall be in the permanent location, properly supported, and the permanent house line piping meets at least one of the following requirements:

1. House line piping is properly connected to all appliance(s) and any unused trunk, branches, and stub piping shall be capped or plugged. Where required, there shall be documentation of an Approval for Natural Gas Service from a Building Code Official; or
2. **PA/MD** – House lines and appliances are NOT installed and an outlet meter valve of sufficient flow capacity is installed to serve the proposed load. The valve shall control all downstream piping and the outlet of the valve capped or plugged.

**OH** – Where approval for natural gas service from the Building Code Official is not required, house line installation(s) shall include at least one appliance drop.

**KY** – House lines and at least one properly connected appliance shall be installed.

**4.3 ABANDONED, TEMPORARILY DISCONNECTED, OR PARTIALLY REPLACED\***

The following are additional requirements for abandoned, temporarily disconnected, or partially replaced customer owned service lines and meter setting installations.

**Exception:** *Abandoned BARE STEEL service lines shall not be reinstated.*

(a) A visual inspection is required only on that portion of the service line that required exposure for work.

(b) Testing shall be in accordance with the following:

1. Service lines abandoned, temporarily disconnected, or partially replaced shall be pressure tested from the point of disconnection to the meter valve in accordance with 4.2 (as NEW) or 4.3(b)4 (BARE STEEL at LOW PRESSURE) before reconnecting. All piping installed for replacement shall be included in the test section.

After completion of the initial test, the piping of the tested section shall be reconnected to the upstream section of the service line. After reconnection when the curb valve has been turned off, the entire service line shall be tested at operating pressure for 3 minutes with no drop in pressure. When the curb valve does not exist or has not been turned off, a CGI test shall be made from the point of reconnection to the customer's property line.

2. As an alternative to 4.3(b)1, the entire service line from curb valve to meter valve may be tested in accordance with 4.2 or 4.3(b)4 after repairs have been made if the service line has a curb valve rated to handle the test pressure.
3. A leakage check at operating pressure shall be made on all exposed fittings in the service line that were disturbed or not included in the pressure test.

**Standards for Customer Service Lines, Meters, and Service Regulators (Plumbers Guide)**

---

4. Service lines containing only BARE STEEL to be operated at a pressure of less than 1 psig (LOW PRESSURE):
  - i. shall be given a pressure test with no drop in pressure at not less than:
    - KY/PA/MD** – 10 psig for at least 5 minutes.
    - OH** – 10 psig for at least 10 minutes.
  - ii. that have a partial replacement involving the riser ONLY:
    - KY/PA/MD** – need not be tested in the same manner as a new service line. The entire service line, including the riser, may be tested at operating pressure for 3 minutes with no drop in pressure.
    - OH** – shall be tested as new.

**Exception:** *If provisions are made to maintain continuous service (such as by installation of a by-pass), any portion of the original service line used to maintain continuous service need not be tested.*

**4.4 REESTABLISHING GAS SERVICE\*****4.4.1 Leak detection**

- (a) When re-establishing service that has been turned off at the curb valve, the customer service line **shall** be tested with natural gas, air, or an inert gas at not less than operating pressure for not less than three minutes with no loss in pressure.
- (b) A CGI test at intervals over the service line is permitted when re-establishing service that has **NOT** been turned off at the curb valve.
- (c) A leakage check shall be made at operating pressure of all exposed fittings in the service line that were not included in the pressure test. An electronic leak detector, combustible gas indicator (CGI), or a leak finder liquid (bubbles) may be used to locate leaks.

**Note:** *In no case shall any gas that affects flammability or produces a toxic atmosphere when burned, such as ether (as an odorant), Freon, oxygen, or acetylene be used to locate leaks.*

**4.5 PURGING PIPELINES\*****4.5.1 Purging with natural gas**

When placed in operation the air in piping can be safely displaced with fuel gas provided that a moderately rapid and continuous flow of fuel gas is introduced at one end of the line and air is vented out at the other end. The fuel gas flow shall be continued without interruption until the vented gas is free of air.

**4.5.2 Purging with air**

There is a greater potential risk of accidental ignition within a pipeline when purging with air because of the slower introduction of air creating a greater area of combustible gas mixtures. When gas piping is to be opened for servicing, addition, or modification, the section to be worked on shall be turned off from the gas supply. The line pressure shall be vented to the outdoors or to ventilated areas of sufficient size to prevent accumulation of flammable mixtures.

**4.5.3 Purge Points\***

- (a) The service line shall be purged prior to checking/setting regulator flow and lock-up.
- (b) The meter inlet shall be connected and purged while observing the meter test dials for movement prior to connecting the meter outlet.

**Standards for Customer Service Lines, Meters, and Service Regulators (Plumbers Guide)**

---

- (c) The house piping shall be purged at all connected appliances prior to placing in operation to prevent injury or property damage.

**Note:** *Piping shall NOT be purged into a confined space or the combustion chamber of an appliance. All potential sources of ignition shall be eliminated. The point of discharge shall NOT be left unattended during purging.*

**4.5.4 Smell Check During Purging**

A combustible gas in a distribution line must contain a natural odorant or be odorized so that the gas is readily detectable by a person with a normal sense of smell. To assure the gas has odorant, each person purging piping into service must conduct a smell check of combustible gases. If the natural gas smell is not readily detectable immediately suspend the purge and notify the Gas Company.

**4.6 RECORD OF RESULTS**

The Gas Company representative will record inspection and test results. If the service line fails the inspection or test, the owner, plumber, or owner's representative will be notified.

## APPENDIX A - Additional Explanatory Material

Appendix A contains additional explanatory material and excerpts from relevant codes numbered to correspond with the applicable text paragraphs.

### A.1.3.2 Arrangements for Establishing Gas Service\*

Gas Company contact phone numbers:

New Business: (800)440-6111

(614)481-1698 - FAX

Customer Contact Center: (800) 344-4077

Note: *Phone numbers are subject to change without notice.*

"Standards for Customer Service Lines, Meters, and Service Regulators" (Plumber's Guide); New Tap and Meter Process, Materials for Customer Service Lines, Standard Drawings for Meter Settings, Operator Qualification Card, Mechanical Joint Card, and Plumber's Guide Revision Proposal Form are available for Ohio @ <http://www.columbiagasohio.com/> and for Pennsylvania and Maryland @ <http://www.columbiagasamd.com/>

### A.2.2.3 Installation of service lines under buildings\*

Some local code officials are interpreting IRC (IFGC) G2415.8 (404.8) and G2415.11 (404.11) to mean that service and/or house lines are not allowed to be installed under buildings, such as garages, and are turning them down. Local code officials should be consulted before allowing any piping under buildings. Follow the guidelines for "Cased Steel Gas Line Laid Under Building" (Plumber's Guide Sketch No. 12).

#### DOT 192.361 Service lines: Installation

(f) *Installation of service lines under buildings.* Where an underground service line is installed under a building:

- (1) It must be encased in a gas tight conduit;
- (2) The conduit and the service line must, if the service line supplies the building it underlies, extend into a normally usable and accessible part of the building; and
- (3) The space between the conduit and the service line must be sealed to prevent gas leakage into the building and, if the conduit is sealed at both ends, a vent line from the annular space must extend to a point where gas would not be a hazard, and extend above grade, terminating in a rain and insect resistant fitting.

**National Fuel Gas Code**, section 7.1.6, "Piping Underground Beneath Buildings" shall be consulted for house lines under buildings.

### A.2.3.2 Steel Service Pipe\*

Welding shall be done by a qualified person in compliance with API (American Petroleum Institute) 1104 *Standard for Welding Pipelines and Related Facilities*; ASME (American Society of Mechanical Engineers) *Boiler and Pressure Vessel Code, Section IX and Section IV*; or AWS (American Welding Society) B2.1 *Specification for Welding Procedure and Performance Qualification*.

### A.2.3.3 Mechanical Fittings\*

Mechanical fittings can be used to join dissimilar materials such as plastic to steel or high density plastic to medium density plastic, and to join different sizes such as 1" to 1 1/4".

**Standards for Customer Service Lines, Meters, and Service Regulators (Plumbers Guide)**

---

**A.2.3.4 Plastic Fusion Fittings\***

(a) Butt Fusion – Not permitted for ½", 1" or mitered cuts. Only fusions for medium-density (yellow) to medium-density, or high-density (black) to high-density are permitted. Use a mechanical joint or an electro-fusion for dissimilar plastics. A mechanical joint shall be used for plastic to steel.

(b) Socket Fusion – Not permitted for sizes 2" and over. Only fusions for yellow to yellow, or black to black are permitted. Use a mechanical joint or an electro-fusion for dissimilar plastics. A mechanical joint shall be used for plastic to steel.

(c) Electro-Fusion – May be used to join dissimilar plastic designations.

**A.2.4 SERVICE LINE SIZING\* – See APPENDIX C - Pipe Sizing.****A.2.5.3 Joining Pipe\* (h)**

Columbia Gas policy and procedure, and DOT require qualification. The "Operator Qualification Card" (Form C-3363) is the Gas Company's method of determining the person making the joint is qualified by DOT Operator Qualification (OQ) Training.

The information area on the front of the form must be completed properly and legibly. All information must be provided and must be signed attesting the person making the joints is qualified to do so. The back of the form is to be completed **ONLY** by Gas Company personnel. See Appendix E for the Operator Qualification Card.

**A.3.1.4 Service Regulators\*****For PA ONLY:**

The customer is responsible for the purchase and installation, or replacement, of the meter setting. The customer will be credited for the cost of the service regulator when applicable.

(a) Customer regulator credit for new sets occurs automatically when the 'Reg Cap' field is checked.

(b) When warranted for existing replacements, the field personnel must issue an "office further action required" and instruct a regulator credit to the customer's account when regulators are replaced.

**A.3.1.5 Regulator Relief Vent\***

Regulator vents shall be located at least 3 ft. left or right (laterally) of, and/or 1 ft. above any atmospheric opening into a building, such as windows or doors. They shall be located at least 10 ft. left or right (laterally) of, and/or 3 ft. above any forced air inlet.

***Note:** Residential Air Conditioners have a negative pressure area of 2' (2'+3'=5') so regulator vents shall be located not less than 5' laterally or 2' above an AC unit. Regulator relief shall be located not less than 8' laterally or 3' above a Natural gas generator location (NFPA 37 requires not less than 5' so 5'+3'=8').*

**A.3.2 METER SETTING LOCATION\***

**(a) Additional Information:** Gas Company P&P 724-42 and DOT 192.351. National Fuel Gas Code 5.7 also has guidelines for premise owned meters. It doesn't apply as code for utility-owned meters, but has good guidelines.

1. The Gas Company reserves the right to determine the location of the meter. The meter should be readily accessible, as near as practical to the point entering the building, not less than 3 ft. from electric panels or meter, furnace, incinerator, or vent connectors. Sources of ignition that may create a negative pressure such as

**Standards for Customer Service Lines, Meters, and Service Regulators (Plumbers Guide)**

air conditioners or power intakes will require not less than 3 ft. from the negative pressure area, usually 5 ft. from residential air conditioners and 8' from generators.

2. Meters shall NOT be located in a small unventilated or confined space, or exposed to extreme temperatures or damage, and may require additional protection if exposed to probable vehicular damage or other hazards.
3. When practical, regulated meter settings should be installed outside of the building away from any openings into the building. Regulators inside buildings must be vented to the outdoors.

See Appendix B for additional meter information.

**A.3.4 METER SIZING\***

**See Appendix B, "Meter Kind & Size, Capacity, and Dimensions".**

Gas meters shall be selected for the maximum expected pressure and permissible pressure drop, which shall not reduce the delivery pressure below the appliance minimum inlet pressure.

***Residential** – input of space and water heating equipment. When the input rate of other appliance(s) such as a pool heater or air conditioner is more than the furnace the total of the greater should be used. In the absence of central heating equipment, load requirements shall be determined from the total input requirements for all appliances.*

***Commercial** – The total input ratings for all connected appliances should be used.*

***Diversity Factor** – The ratio of the maximum probable demand to the maximum possible demand shall always be considered for sizing meters.*

**A.3.6.1 Distribution Notification\* (High-pressure settings)**

Approval forms are required from both the **Pipeline Company** (e.g., TCO) and the **Gas Company**. The customer will pay an aid-to-construction charge. The Gas Company, upon approval and payment, will provide first- and, if required, second-cut regulators and build the high-pressure setting on the pipeline.

PA: The final-cut service regulator, or pre-fabricated meter setting, shall be customer-purchased and installed to provide gas to the house lines from the meter located in the easement.

**A.4.2.1 New Construction Pressure Test Requirements (2" and under)\* &**

**A.4.3 ABANDONED, TEMPORARILY DISCONNECTED, OR PARTIALLY REPLACED\***

**Service Line Testing**

<b>Service Lines 2" &amp; Under, New or Repaired, P&amp;P 725-4</b>		
<b>Test Requirements:</b>	<b>Time</b>	<b>Pressure</b>
MAOP 60 psig or less	5 minutes	90 psig
MAOP more than 60 psig	5 minutes	1.5 x MAOP

*Note: MAOP is the Maximum Allowable Operating Pressure.*

**Standards for Customer Service Lines, Meters, and Service Regulators (Plumbers Guide)**

<b>Service Lines Over 2", New or Repaired, P&amp;P 725-3</b>			
<i>(See P&amp;P 725-3, Exhibit A.)</i>			
Test Requirements:	Time		Pressure
	less than 200'	200' or more	
MAOP 60 psig or less	1 hour	L X (D X D) / 8000	90 psig
MAOP more than 60 psig*	1 hour	L X (D X D) / 8000	1.5 x MAOP*

*\*Up to 30% SMYS (Specified Minimum Yield Strength).*

<b>Service Line Testing, Existing, P&amp;P 725-5</b>		
Test Requirements:	Time	Pressure
Pressure Drop Test	3 minutes	Operating
CGI Test - at intervals over the service line and in the vicinity of the curb box.		

**NOTES for Abandoned, Temporarily Disconnected or Partially-Replaced Service Lines:**

(a) Service lines previously **abandoned** shall be tested in the same manner as new service lines before reinstated.

**Exception:** *Abandoned BARE STEEL service lines shall not be reinstated.*

(b) Service lines **temporarily disconnected** or **partially replaced** shall be tested as new.

1. Service lines **temporarily disconnected** or **partially replaced** shall be tested from the point of disconnection to the meter valve in the same manner as new service lines before reconnecting. Replaced piping shall be included in the test section. The piping of the tested section shall be reconnected to the upstream section of the service line and the entire line shall be tested at operating pressure for 3 minutes with no drop in pressure.
2. Service lines **temporarily disconnected** or **partially replaced** may be reconnected and the entire customer-owned service line, to the meter valve, tested as new.

**Exceptions:**

1. **Low pressure BARE** (see P&P 725-7) **STEEL** service lines will be given a pressure test at not less than **10 psig for at least 5 minutes (10 min. in OH)** with no drop in pressure.
2. A **partial replacement** involving **the riser only on a low pressure BARE STEEL** service line (P&P 725-7, 3.2) need not be tested in the same manner as a new service line provided the entire service line, including the riser, is tested at **operating pressure for 3 minutes** with no drop in pressure after completion of the replacement. **In OH, the riser shall be tested as new.**

**A.4.5 PURGING PIPELINES\***

Combustible gas air mixtures will be present at both the discharge point and within the pipeline at some point during the purge so elimination of potential sources of ignition is crucial. Venting hazardous amounts of gas is not permitted unless specific safety requirements, including but not limited to additional personnel standing by with a fire extinguisher and control through signs, tape, and other personnel to control the perimeter, are used. Pipe volumes indicated by NFGC Tables 7.3.1 and 7.3.2 shall be displaced with an inert gas such as nitrogen or carbon dioxide.

**Standards for Customer Service Lines, Meters, and Service Regulators (Plumbers Guide)**

---

**A.4.5.3 Purge Points\***

Only a representative of the Gas Company is permitted to open the curb valve or reconnect a meter. Gas Company personnel shall purge at the service line prior to setting regulator lockup and flow, at the meter outlet to ensure proper meter operation, and at all connected appliances prior to placing in operation to prevent injury or property damage.

Standards for Customer Service Lines, Meters, and Service Regulators (Plumbers Guide)

**APPENDIX B - Meter Kind & Size, Capacity, and Dimensions**

Notes:

1. Meters operating at 7" w.c. should be sized based on a 0.5" w.c. differential.
2. Meters operating at 0.5 psig to 2 psig may be sized based on a 1.0" w.c. differential.
3. Meters operating at 2 psig or greater may be sized based on a 2.0" w.c. differential.
4. For meter setting drawings, consult the Gas Company.

\* Index on top of meter is higher than top of swivel when set.

Meter Name	Kind & Size	Model Number	Capacity [cfh]			Pipe Size	Spread Center [in.]	Height w/ Swivels [in.]	Meter Dimensions [in.]		
			1/2" Drop	1" Drop	2" Drop				Height	Width	Depth
American* (Singer)	602	AL175	175	260	375	1 or 1-1/4	6	16.125	13.125	8.75	8.75
	604	5B225	225		NA	1 or 1-1/4	6	16.75	13.75	9.625	8.5
	608	AC250	250	375	540	1 or 1-1/4	6	16.75	13.75	8.625	8.75
	614	AR250	250	375	540	1	6	14	11	8.25	8.12
	616	AL425	425	625	900	1-1/4	8.25	18	14.875	10.75	10.1875
	619	AC630	630	940	1,355	1-1/4	8.25	18	14.875	10.75	10.1875
	612	AL800	800	1,150	1,700	1-1/2	11	23.5	23.5*	14.125	13.25
	611	AL1000	1,000	1,450	2,200	1-1/2 or 2	11		23.5625	14.125	13.25

\* see page B2 for American Ironcase

Lancaster	870	240/250	250	375	540	1 or 1-1/4	6	18	14	10	8
-----------	-----	---------	-----	-----	-----	------------	---	----	----	----	---

Invensys (Equimeter, Rockwell)	815	175	175	260	375	1 or 1-1/4	6	17	13	10	9
	814	R175	220		NA	1 or 1-1/4	6	18	13.5	11	10
	817	R200	200	300	430	1 or 1-1/4	6	18	13.5	11	10
	818	250	250	375	540	1 or 1-1/4	6	18	13.5	11	10

**Standards for Customer Service Lines, Meters, and Service Regulators (Plumbers Guide)**

Meter Name	Kind & Size	Model Number	Capacity [cfh]			Pipe Size	Spread Center [in.]	Height w/ Swivels [in.]	Meter Dimensions [in.]		
			1/2" Drop	1" Drop	2" Drop				Height	Width	Depth
	823	R275	275	410	590	1	6	18	13.375	10.125	8.5
	820	415	415	620	890	1-1/2	8	21	17	13	10
	821	750	750	1,100	1,600	1-1/2	11	23.75	23.75*	17	13.75
	822	800	800	1,100	1,600	1-1/2	11	23.75	23.75	17	13.75

Actaris (Schlumberger, Sprague)	718	1A	175		NA	1	6	18	14	10	8
	755	175	215	320	465	1 or 1-1/4	6				
	761	250	250			1	7.1875	19	16	11	9
	726	2	305			1-1/4	6.75	21	18	12	10
	765	400A	400	600	900	1-1/4	6.75	14.75	14.75	11	8.75
	730	3	400			1-1/4 or 1-1/2	10	27	22.5	16	14
	751	675A	625	1,050	1,650	2	10	23.25*	23.2*	16	14
	738	4	675		1,550	1.5	10.875	30	25	18	16
	766	800A TC	800	1,250	1,850	2	11	23.25*	23.2*	16	14
	746	5	856		1,700	2	10.875	30	25	18	16
	767	1000A TC	1,000	1,500	2,300	2	11	23.25*	23.2*	16	14
746	5A	1,000		2,300	2	10.875	32	27	18	16	

Superior	829	AL175A	250		NA	1 or 1-1/4	6	17	14	10.25	9.25
	830	AL250	250		NA	1 or 1-1/4	6	17	14	10.25	9.25

American (Ironcase)	622	5B	165		NA	1 or 1-1/4	6	18	15	9	11
	630	10B	250		NA	1 or 1-1/4	6.875	19	15.5	10	11

**Standards for Customer Service Lines, Meters, and Service Regulators (Plumbers Guide)**

Meter Name	Kind & Size	Model Number	Capacity [cfh]			Pipe Size	Spread Center [in.]	Height w/ Swivels [in.]	Meter Dimensions [in.]		
			1/2" Drop	1" Drop	2" Drop				Height	Width	Depth
	642	30B	550		1,100	1-1/2	11	26	22	16	15.25
	646	35B	650		1,500	1-1/2	11	25.5	21.5	15.5	15.75
	650	60B	950		2,000	2	13.125	31	26	18	18

Romet	762	23M	23,000	Not	Applicable	4	9.5	NA	9.5	30.25	12
-------	-----	-----	--------	-----	------------	---	-----	----	-----	-------	----

Roots / Dresser	743	11C	1,100	Not	Applicable	2	6.75	NA	6.75	15	6
	744	15C	1,500	Not	Applicable	2	6.75	NA	6.75	16	6
	741	2M	2,000	Not	Applicable	2	6.75	NA	6.75	16	7
	745	3M	3,000	Not	Applicable	2	6.75	NA	6.75	18	7
	747	5M	5,000	Not	Applicable	3	6.75	NA	6.75	20	7
	748	7M	7,000	Not	Applicable	3	9.5	NA	9.5	18	9
	749	11M	11,000	Not	Applicable	4	9.5	NA	9.5	22	9
	750	16M	16,000	Not	Applicable	4	9.5	NA	9.5	25	9

*Note: Capacity of Romet and Roots rotary meters is the manufacturer's rated capacity, and is not sized for a pressure drop.*

## APPENDIX C - Pipe Sizing

### How to Size a Gas Service Line

In determining the size of service lines to be used in designing a gas piping system, ALL SIX of following factors must be considered:

1. **Pipe Material** (plastic pipe or steel pipe)

*Note:* Plastic pipe tables are in the *Plumber's Guide*.

*Steel Pipe requires special tables or calculations.*

2. **Gas supply pressure**

**Low Pressure** – normally 7 to 14 inches of water column.

**Intermediate Pressure** – normally 2 to 10 psig, but may drop to **1 psig** during times of high demand.

**Medium Pressure** – normally 10 to 60 psig, but may drop to **2 psig** during times of high demand.

**High Pressure** – over 60 psig, and may exceed 1000 psig.

3. **Allowable loss in pressure from the main to the meter**

Tables provide for:

**Low pressure - 0.5" w.c.**

**Intermediate pressure - 5.0" w.c.**

**Medium pressure - 16" w.c.**

**High pressure – 2 psig**

4. **Specific gravity and Heating Value content of the gas**

Columbia distributes **Natural Gas** with a Specific Gravity of **0.6** and a normal Heating Value of **1000 Btu's/cu. ft.**

5. **Length of the service line, from the main to the meter**

6. **Gas demand in Cubic Feet / Hour (CFH)**

**Residential** – input of furnace and water heater. In the absence of central heating equipment, load requirements shall be determined from the total for all appliances.

**Commercial** – input of all connected appliances.

**Diversity Factor** – ratio of the maximum probable demand to the maximum possible demand.

*Note:* Btu rating of gas appliances divided by 1000 = CFH.

**TABLE 1**

**Maximum Capacity of Plastic Pipe in CFH for Service Lines Operated at Low Pressure**

(Based on a Pressure Drop of 0.5" Water Column and 0.6 Specific Gravity Gas.)

MDPE Plastic	<u>Distance Main to Meter in Feet</u>						
	10	50	100	150	200	250	300
1" CTS	373	167	118	96	83	75	68
1 1/4" IPS	1074	480	340	277	244	215	196
2" IPS	3,160	1,410	1,000	820	710	630	580
3" IPS	9,280	4,150	2,940	2,400	2,030	1,860	1,700
4" IPS	18,430	8,240	5,830	4,760	4,120	3,690	3,360
6" IPS	51,820	23,180	16,390	13,380	11,590	10,360	9,460

Table has allowed for normal fittings.

**Low-Pressure Service Lines.** Low-pressure customer service lines shall not be less than 1 inch CTS.

**Standards for Customer Service Lines, Meters, and Service Regulators (Plumbers Guide)**

**TABLE 2**

**Maximum Capacity of Plastic Pipe in CFH for Service Lines Operated at Intermediate Pressure (1 psig minimum)**

(Based on a Pressure Drop of 5.0" Water Column and 0.6 Specific Gravity Gas.)

MDPE Plastic	<u>Distance Main to Meter in Feet</u>						
	10	50	100	150	200	250	300
3/4" CTS *	450	230	170	140	120	110	100
1" CTS	750	480	360	300	270	240	220
1 1/4" IPS	1,690	1,200	940	800	710	640	590
2" IPS	2,410	2,180	1,970	1,810	1,680	1,580	1,490
3" IPS	10,530	8,700	7,360	6,490	5,880	5,410	5,030
4" IPS	20,890	17,260	14,600	12,890	11,660	10,730	9,990

\* ONLY piping and reducing fittings are approved, and for insertion in 1 inch metallic pipe.

Table has allowed for normal fittings.

**Intermediate-Pressure Service Lines.** Intermediate-pressure customer service lines shall not be less than 3/4 inch CTS.

**Exception:** Prior approval from the Gas Company Engineering Department shall be obtained to install 1/2 inch CTS (5/8 inch OD) piping on systems specifically designed to operate at 1 psig minimum pressure.

**TABLE 3**

**Maximum Capacity of Plastic Pipe in CFH for Service Lines Operated at Intermediate\* or Medium Pressure (2 psig minimum)**

(Based on a Pressure Drop of 16" Water Column and 0.6 Specific Gravity Gas.)

MDPE Plastic	<u>Distance Main to Meter in Feet</u>						
	10	50	100	150	200	250	300
1/2" CTS	470	220	150	120	105	93	84
3/4" CTS **	1,060	640	470	390	330	300	270
1" CTS	2,290	1,380	1,010	830	720	640	578
1 1/4" IPS	4,660	3,190	2,450	2,040	1,780	1,600	1,460
2" IPS	5,750	5,140	4,590	4,180	3,850	3,590	3,370
3" IPS	24,380	19,720	16,380	14,250	12,760	11,630	10,740
4" IPS	48,870	39,530	32,830	28,570	25,570	23,310	21,530

\* If the system is Intermediate Pressure (IP) and the minimum pressure is not known, use Table 2 – Intermediate Pressure (1 psig minimum).

\*\* ONLY piping and reducing fittings are approved, and for insertion in 1 inch metallic service lines.

Table has allowed for normal fittings.

**Medium-Pressure Service Line.** Medium-pressure customer service lines shall not be less than 1/2 inch CTS.

**TABLE 4**

**Maximum Capacity of Plastic Pipe in CFH for Service Lines Operated at High Pressure (61 psig minimum)**

(Based on a Pressure Drop of 2 psig and 0.6 Specific Gravity Gas.)

HDPE Plastic	<u>Distance Main to Meter in Feet</u>						
	10	50	100	150	200	250	300
1/2" CTS	1,920	980	690	560	480	420	380
1" CTS	9,990	6,170	4,560	3,750	3,250	2,900	2,640
1 1/4" IPS	21,390	14,650	11,220	9,370	8,190	7,340	6,700
2" IPS	26,370	23,580	21,050	19,150	17,670	16,470	15,470
3" IPS	111,830	90,450	75,130	65,380	58,510	53,340	49,280

Table has allowed for normal fittings.

**High-Pressure Service Line.** High-density polyethylene plastic (HDPE – black PE-3408/3608) may be installed to a maximum pressure of 99 psig.

## APPENDIX D - Sketches

Sketch No. 1 - Typical Service Line Locations

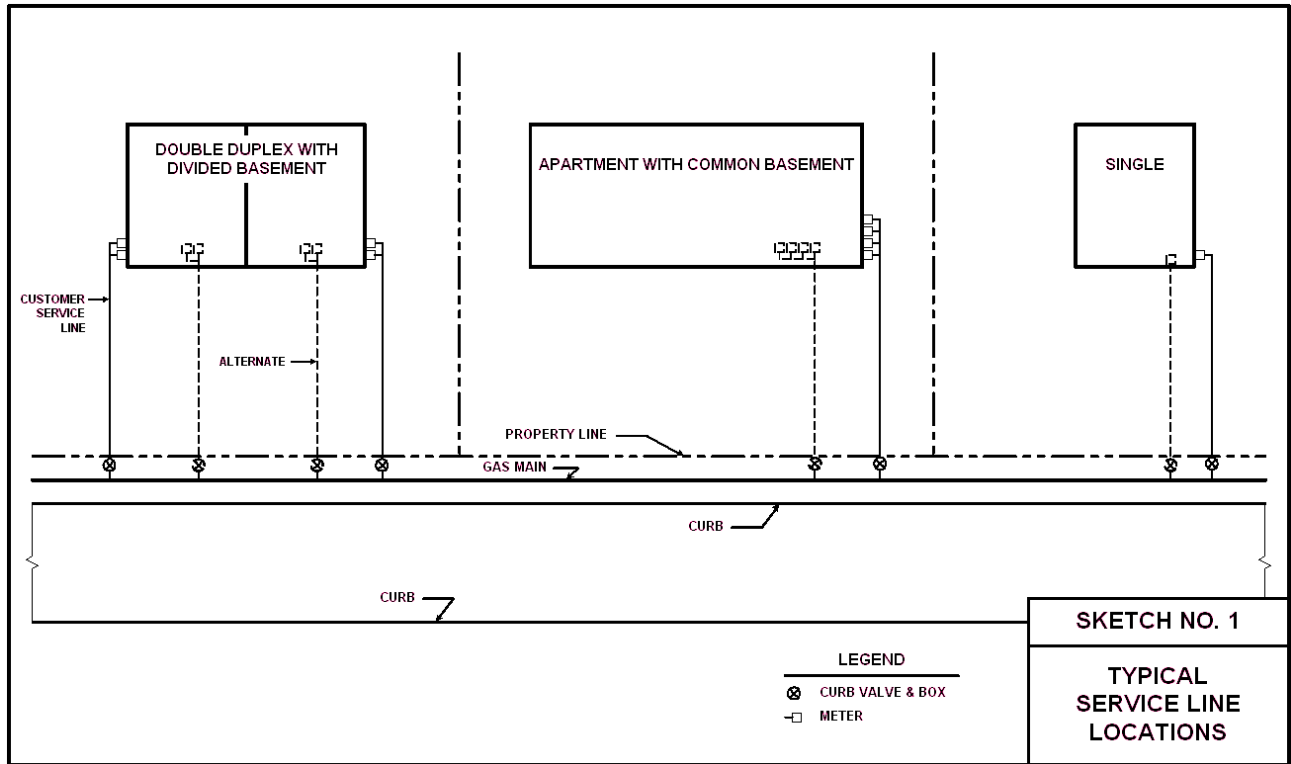

Sketch No. 2 - Typical Service Line and Curb Valve Locations

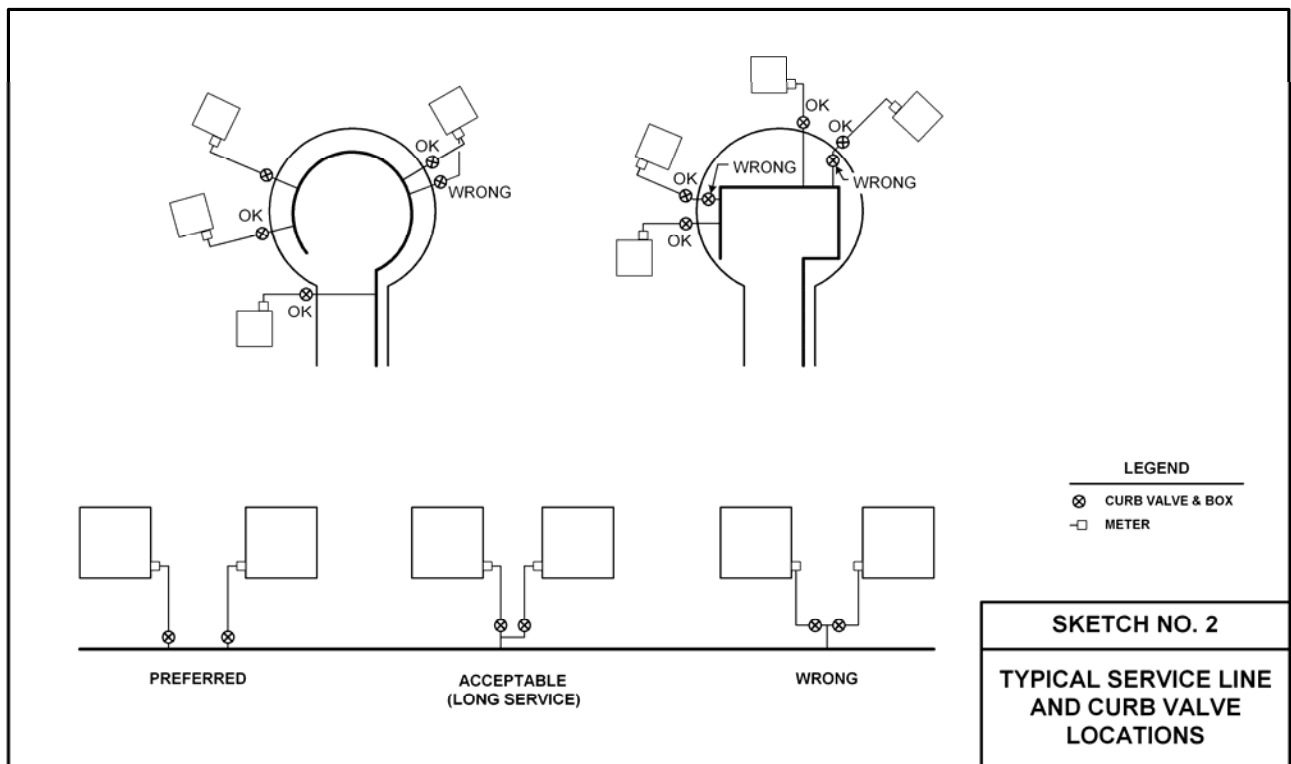

Standards for Customer Service Lines, Meters, and Service Regulators (Plumbers Guide)

Sketch No. 3 - 2 inch Riser Piping Details

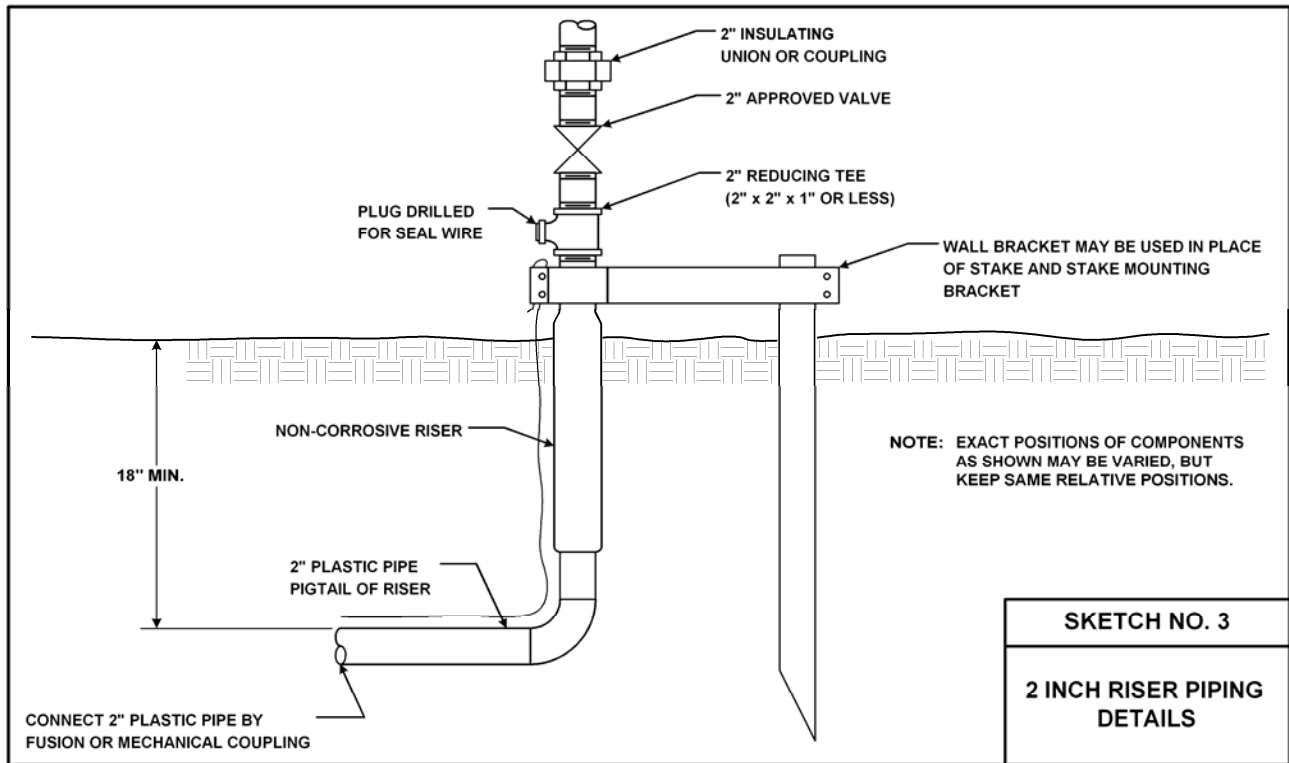

Sketch No. 4 - Direct Burial Plastic Service Line

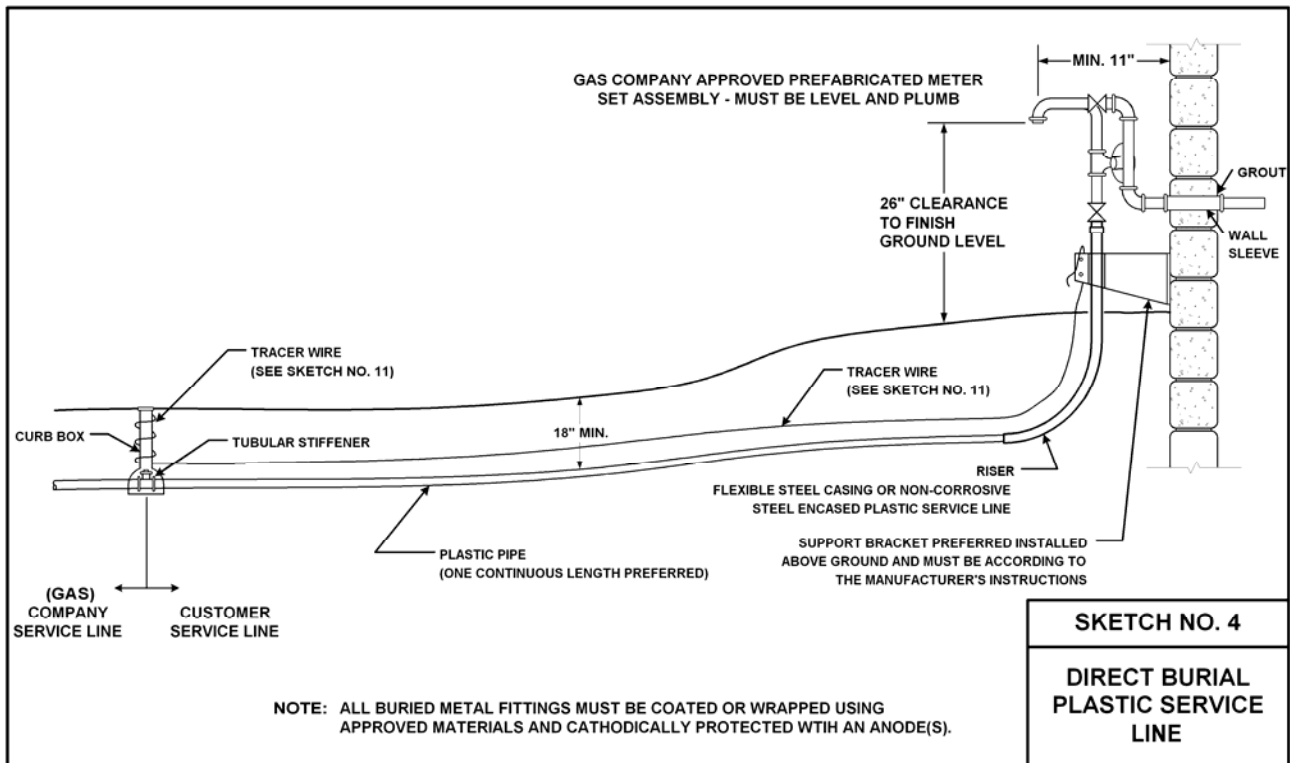

Standards for Customer Service Lines, Meters, and Service Regulators (Plumbers Guide)

Sketch No. 5 - Service Line Under Paved Area

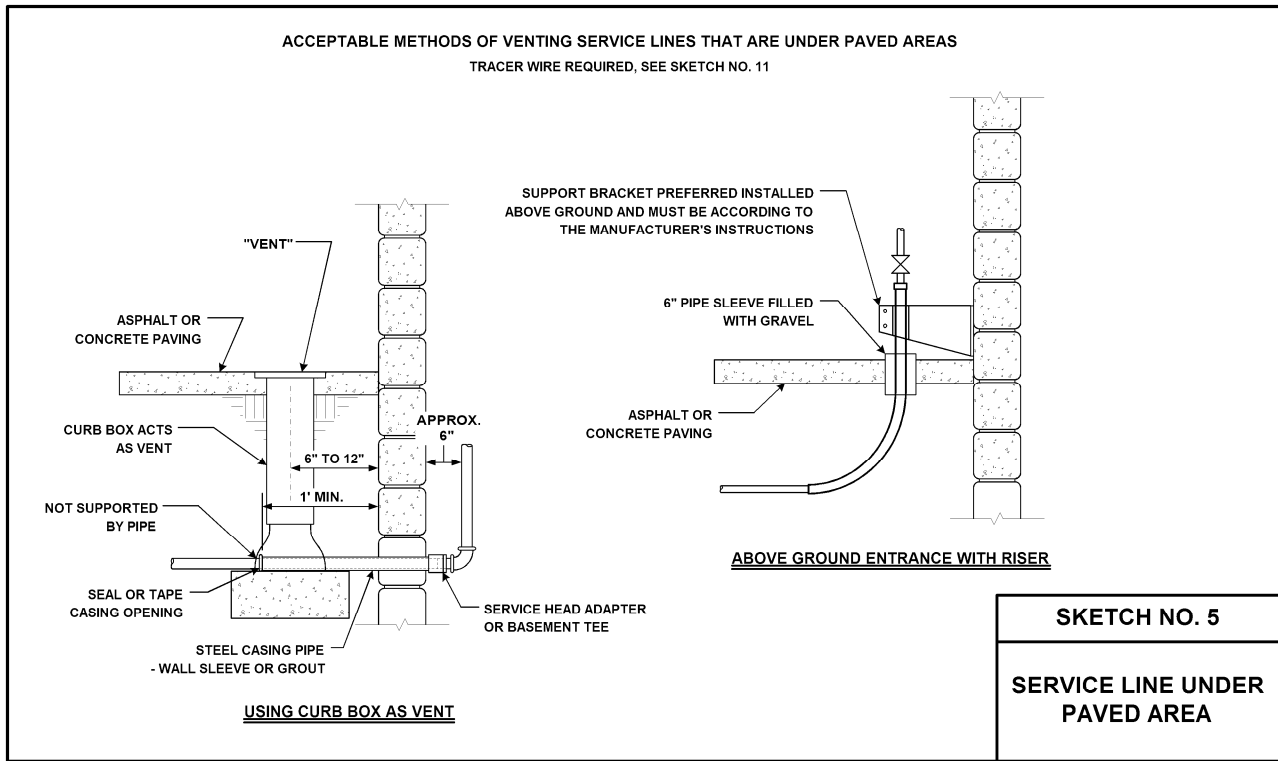

Sketch No. 6 - Entrance for Plastic Service Line

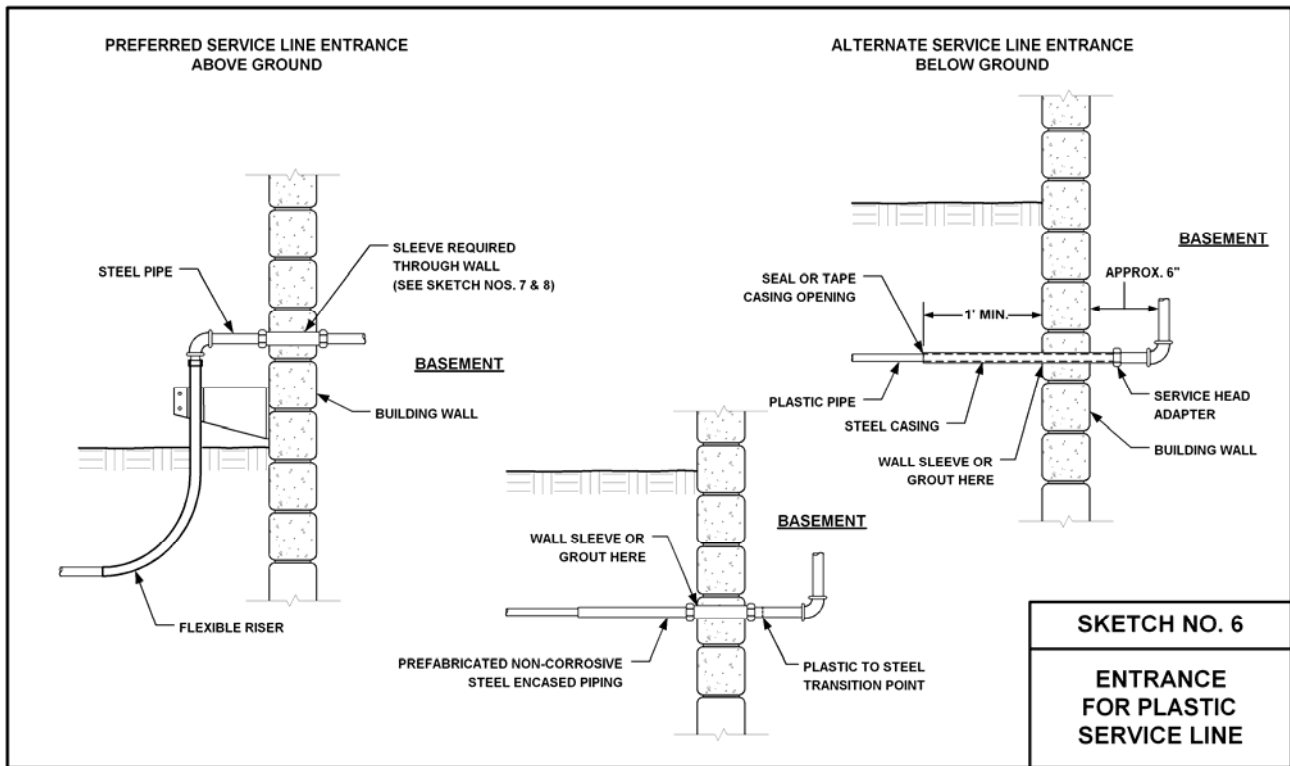

Standards for Customer Service Lines, Meters, and Service Regulators (Plumbers Guide)

Sketch No. 7 - Sleeves for Masonry Wall Entrances

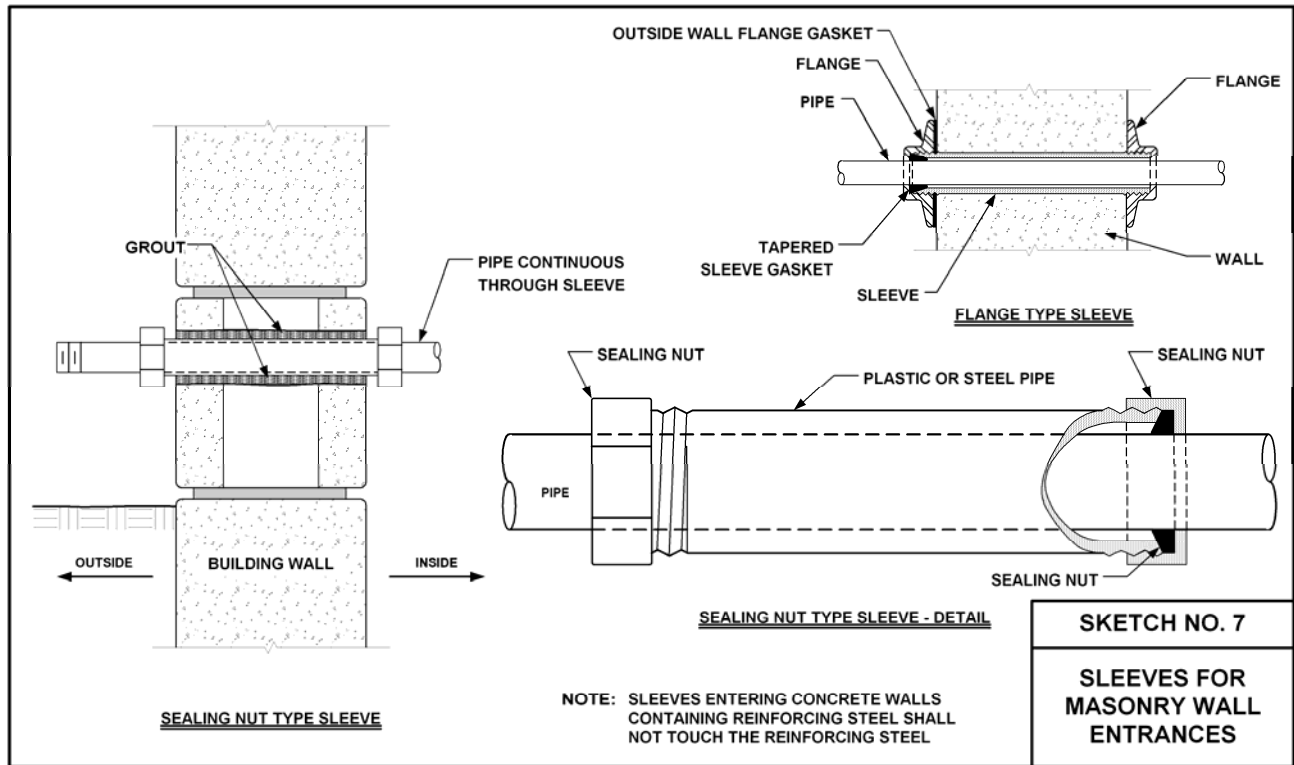

Sketch No. 8 - Prefabricated Masonry Wall Entrances

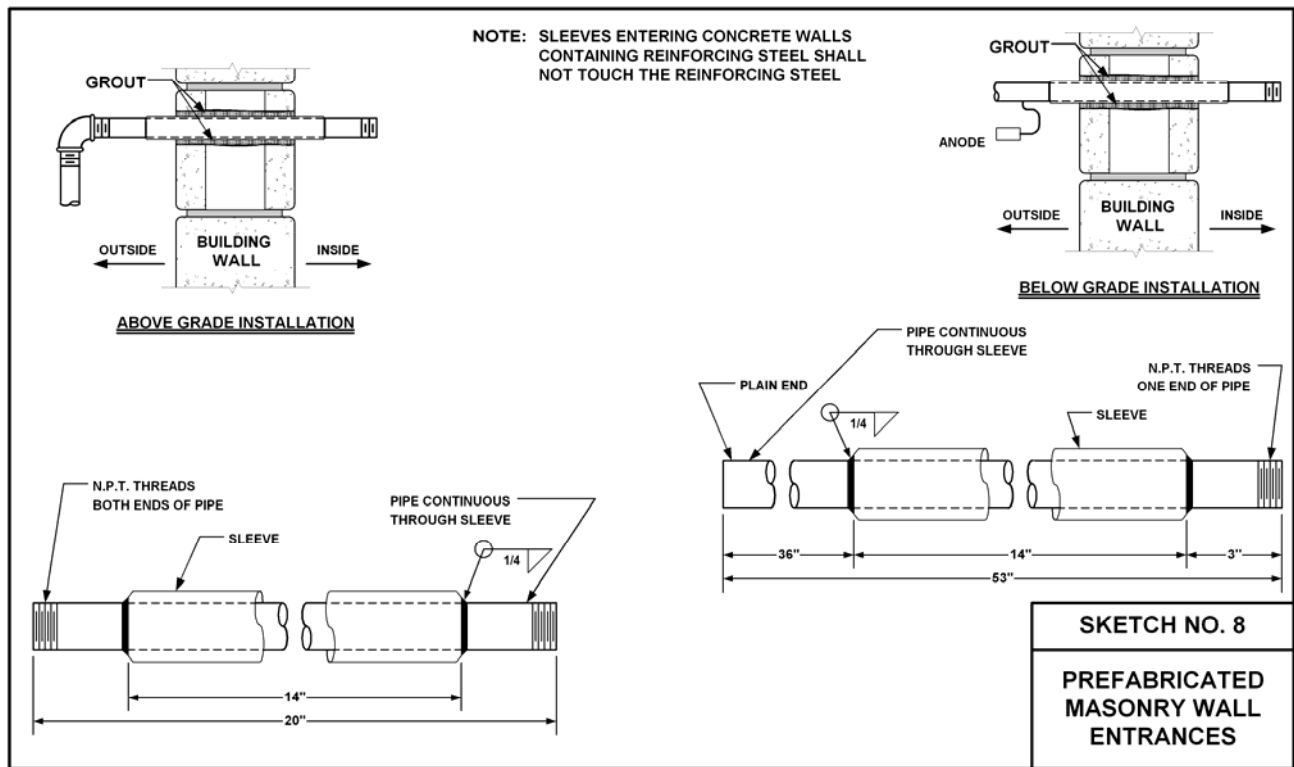

**Sketch No. 9 - Mobile Home Installations**

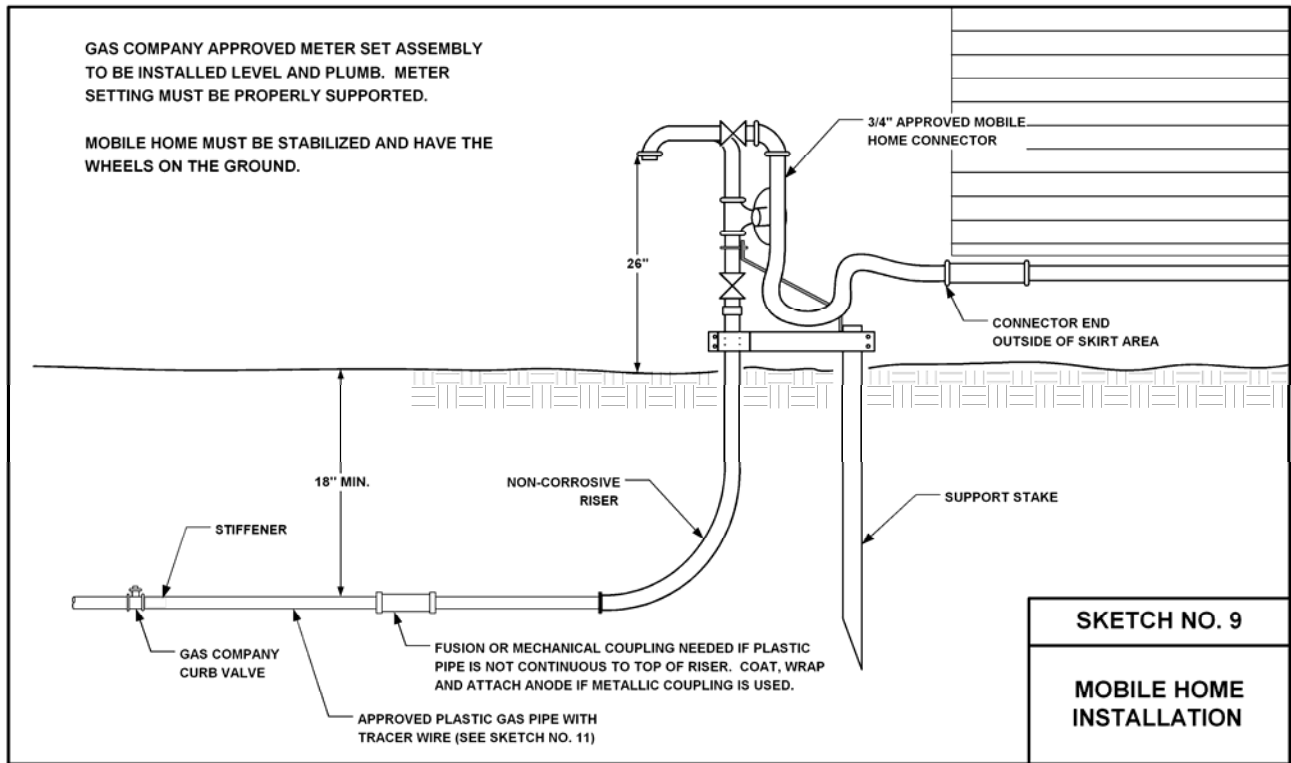

**Sketch No. 10 - Remote Meter Set Details**

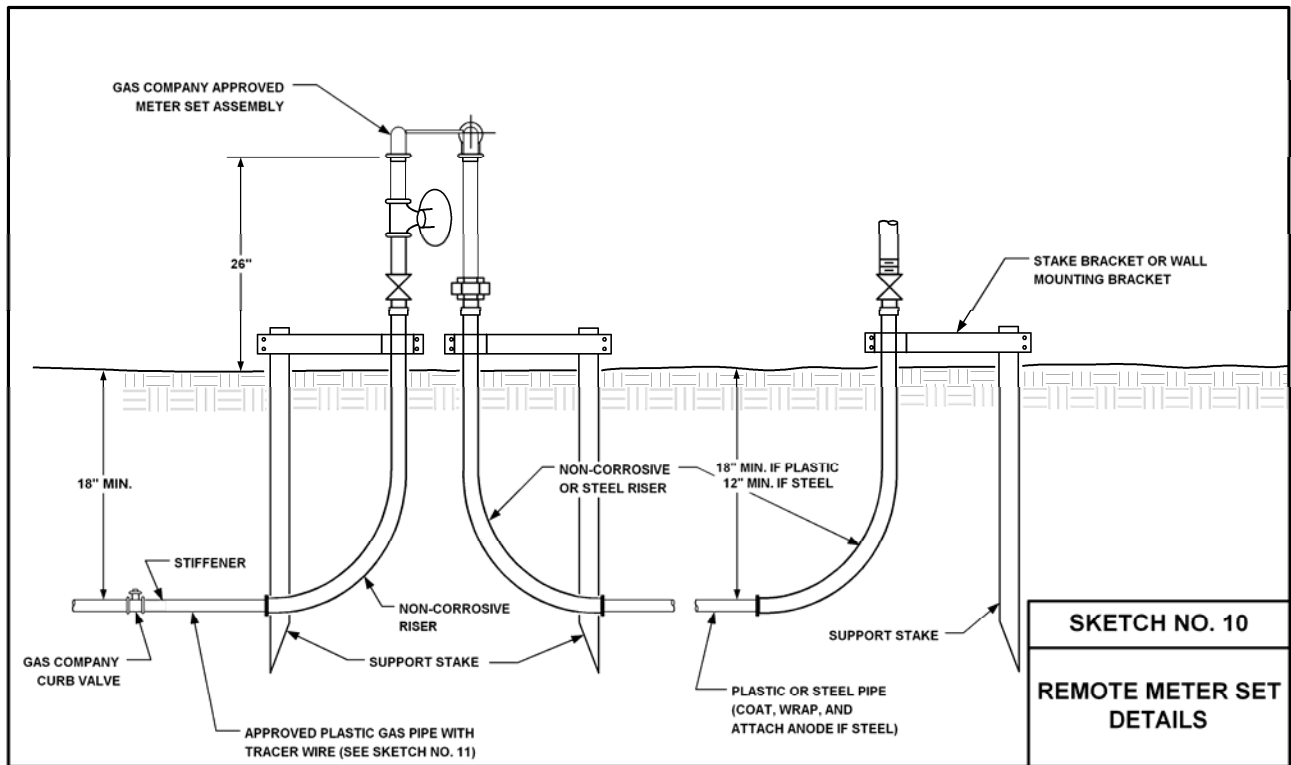

**Sketch No. 11 - Tracer Wire Details**

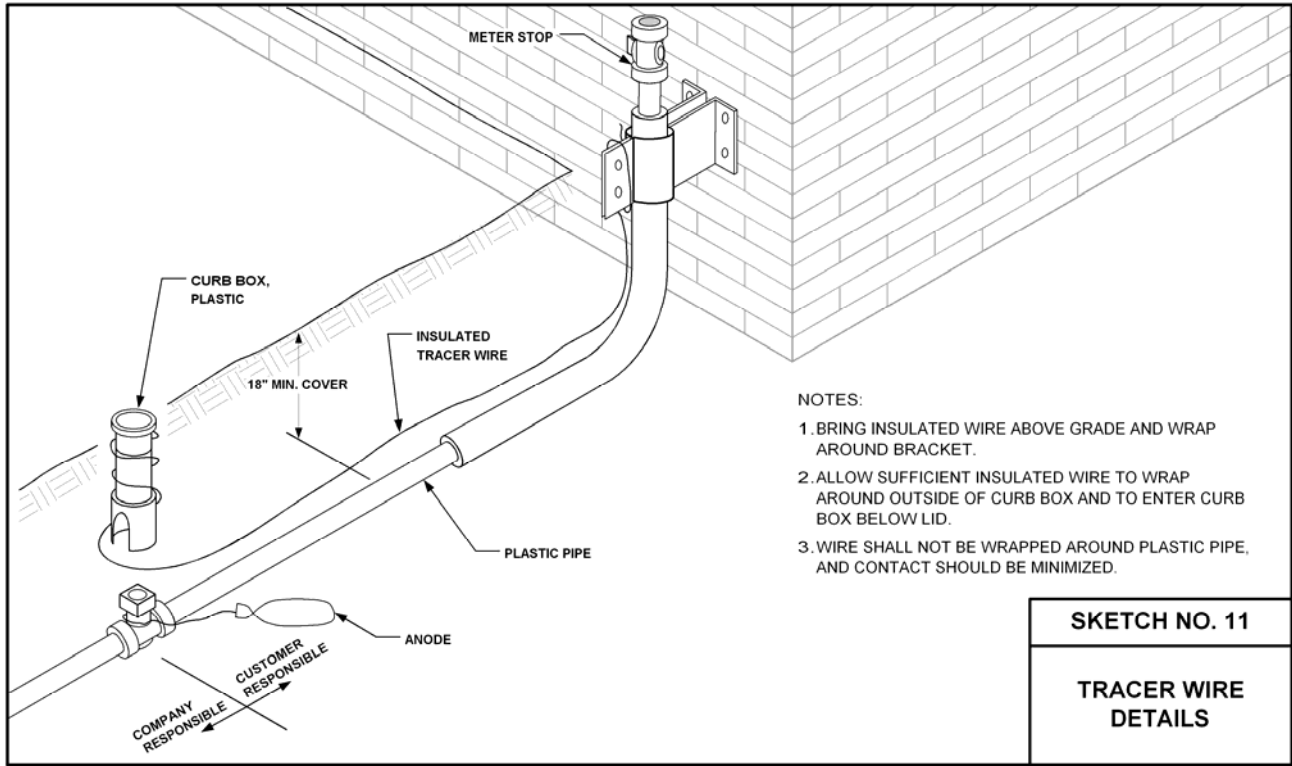

**Sketch No. 12 - Cased Steel Gas Line Laid Under Building**

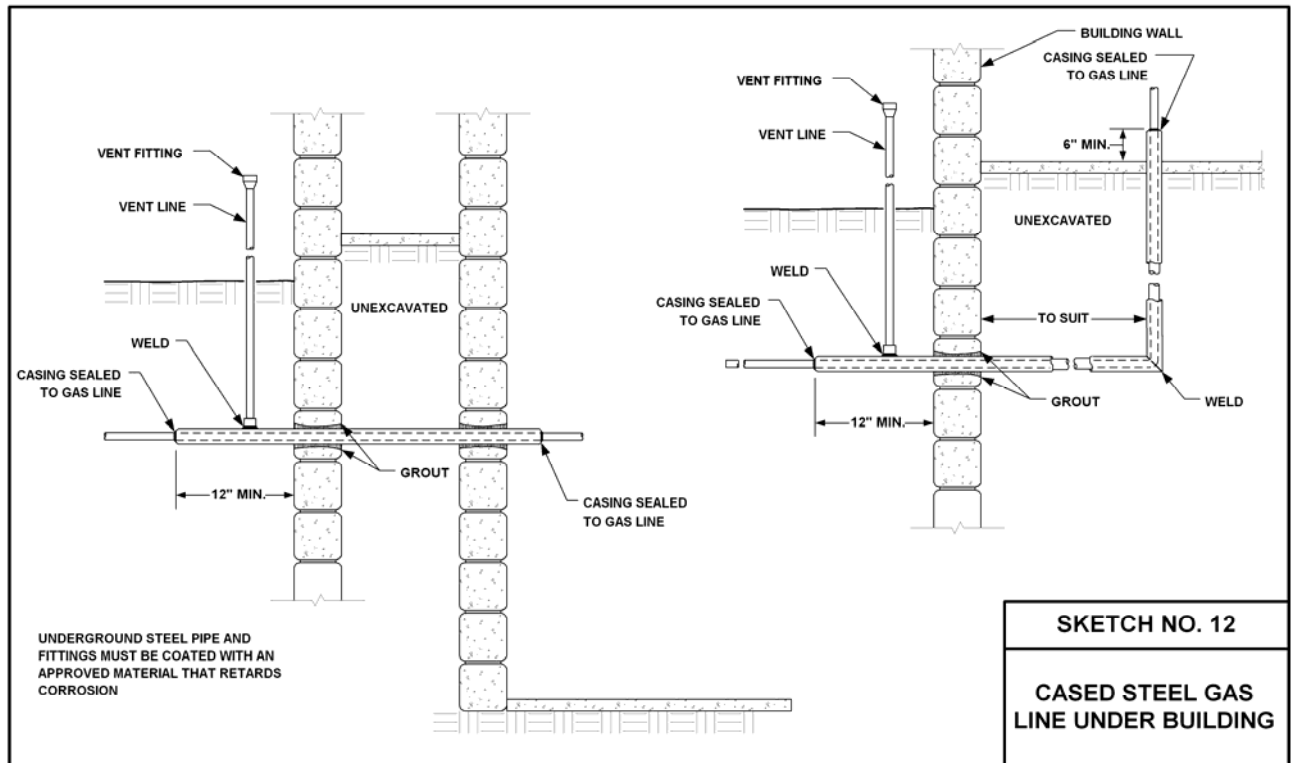





**Instructions for Submitting a Revision Proposal to the Plumber's Guide (Columbia Gas Standards for Customer Service Lines, Meters, and Service Regulators; Form C 2235)****Methods submitting a proposal:**

1. Contact any of the personnel listed by state at the bottom of this page.
2. Complete and submit the proposal electronically @ <http://www.columbiagasohio.com> (go to "Your Business", then click on "Information for Builders and Plumbers").
3. Complete and submit the proposal in paper copy to **any of the personnel listed below**, or to:  
Columbia Gas of Ohio  
Attn: Richard Losey  
1600 Dublin Rd.  
Columbus, OH 43215

Please contact us if you have any questions.

Thank you, for your assistance.

---

**Kentucky**

**Rick Johnson**, Technical Support Specialist, 2001 Mercer Rd., Lexington, KY 40512

Phone: (859) 288-0293, FAX: 859-288-0258, e-mail: [rjohns2@nisource.com](mailto:rjohns2@nisource.com)

**Tim McKune**, Compliance Specialist, 2001 Mercer Rd., Lexington, KY 40512

Phone: (859) 288-0241, FAX: 859-288-0258, e-mail: [tmckune@nisource.com](mailto:tmckune@nisource.com)

**Ohio**

**E. Larry Springer**, Technical Trainer, 1600 Dublin Rd. EW-Rm 118, Columbus, OH 43215

Phone: (614) 481-1444, FAX: (614) 481-1004, e-mail: [espringer@nisource.com](mailto:espringer@nisource.com)

**Paul DeBlasis**, Technical Trainer, 300 Luray Dr., Wintersville, OH 43953

Phone: (740) 266-5946, FAX: (740) 264-0448, e-mail: [pdeblasis@nisource.com](mailto:pdeblasis@nisource.com)

**Charles "Chuck" McKenna**, Technical Trainer, Norwalk, OH

Phone: (419) 427-3217, FAX: (419) 427-3217, e-mail: [cjmckenna@nisource.com](mailto:cjmckenna@nisource.com)

**Barry S. Mullins**, Technical Trainer, 843 Piatt Av., Chillicothe, OH 45601

Phone: (740) 772-9137, FAX: (740) 773-1902, e-mail: [bmullins@nisource.com](mailto:bmullins@nisource.com)

**Dawn Bass**, Program Specialist, 1600 Dublin Rd. EW-1, Columbus, OH 43215

Phone: (614) 481-1107, FAX: (614) 481-1004, e-mail: [dbass@nisource.com](mailto:dbass@nisource.com)

**Richard Losey**, Standards Engineer, 1600 Dublin Rd. EW-1, Columbus, OH 43215

Phone: (614) 481-1101, FAX: (614) 481-1004, e-mail: [rlosey@nisource.com](mailto:rlosey@nisource.com)

**Pennsylvania / Maryland / Virginia**

**Mike Breighner**, Training Manager, 1020 N. Hartley, York, PA 17404

Phone: (717) 849-0159, FAX: (717) 767-0204, e-mail: [mbreigh@nisource.com](mailto:mbreigh@nisource.com)

**Randy Presnar**, Technical Trainer, 2737 W. State St., New Castle, PA 16101

Phone: (724) 546-2221, Cell: (724) 321-7129, Fax: (724) 658-5068,

e-mail: [rpresnar@nisource.com](mailto:rpresnar@nisource.com)

**Phil Toomey**, Standards Specialist, 1020 N. Hartley, York, PA 17404

Phone: (717) 849-0136, FAX: (717) 767-0204, e-mail: [ptoomey@nisource.com](mailto:ptoomey@nisource.com)

**Dave Bowman**, Compliance Manager, 1809 Coyote Dr., Chester, VA 23836

Phone: (804) 768-6404, FAX: (804) 768-5913 e-mail: [dbowman@nisource.com](mailto:dbowman@nisource.com)

**Tom Hickman**, Technical Trainer, 203 N. Madison St., Petersburg, VA 23803

Phone: (804) 861-9551 ext. 28, FAX: (804) 861-4182, e-mail: [thickman@Nisource.com](mailto:thickman@Nisource.com)

# INDEX

In addition to the Index, refer to the Definitions section for more information.

Abandoned.....	2.1.5(d)	Joining.....	<b>2.5.3</b> , 2.3.4
<b>Accessibility</b>		Leak Detection.....	4.4.1
<b>Meter Setting</b> .....	<b>3.2.2</b>	Length of Piping.....	2.4.5
<b>Piping</b> .....	<b>3.2.3</b>	<b>Level Meter Set</b> .....	<b>3.3.6</b>
Adapter Fittings.....	2.6.3(f), 2.3.5, 2.2.2(b)1	Load.....	3.4.0, 2.4.6
Advisory Service.....	1.2	Appliance.....	2.4.6
All Thread Nipples.....	2.3.5(b)	Location.....	1.5(a), 1.3.1(b), 1.2(c)
Arrangements.....	4.1.2(a)	<b>Meter Setting</b> .....	4.2.4(a), 3.2.6, 3.2.3, 3.2.1(a), 3.2
<b>Arrangements for Service</b> .....	<b>1.3.2</b>	<b>Regulator</b> .....	<b>3.6.2</b> , <b>3.2.7</b>
Asphalt.....	2.3.6(b)	<b>Service Line</b> .....	2.2.1(a), <b>2.2</b>
Backfill.....	2.5.6(c)	Vent.....	3.2.7(a), 3.1.5(a)3.ii, 3.1.5
<b>Bends</b> .....	<b>2.5.4</b>	Manifold.....	3.3.4, 3.3.2(a), 2.1.5(c), 2.1.5(b)
Building		Manufactured Homes.....	1.1(e)2, See Mobile Homes, p. ii
Access.....	4.1.2(b)3, 1.3.2(d)3	Meter Settings.....	3.1.3
Service.....	2.1.2	Mobile Homes.....	1.1(e)3
Service Location.....	2.2.3(a), 2.2.2, 2.2.1(b)	New Construction.....	<b>4.2.1</b> , 4.1.2(b)2
Wall.....	2.3.6(a)	New Service Lines.....	4.2
Cast Iron Fittings.....	2.3.5(b)	Operator Qualification Card.....	2.5.3(d)2
Cathodically Protected.....	3.3.9(b), 2.5.3(e), 2.3.3(b)	Ownership.....	3.1.4(b), 3.1.1(c), 1.5(b)
Charges.....	<b>4.1.1</b> , 1.4	Pipe	
Clearance		Steel... ..	2.5.3(a), 2.4.1, 2.3.2, 2.2.2(b)1, 1.1(b)
<b>Meter</b> .....	<b>3.3.5</b>	Plastic	
Utilities.....	2.5.2(d)	High Density.....	2.4.2, 1.6
Conduit.....	2.5.1(e), 2.2.3(b)1	Medium Density.....	1.6
<b>Connector</b>		Plastic Pipe.....	2.6.3(d), 2.5.6(e), 2.5.6(c), 2.5.3(g), 2.5.3(f), 2.5.3(b), 2.5.1(j), 2.5.1(i), 2.5.1(g), 2.5.1(f), 2.5.1(e), 1.1(b)
<b>Manufactured Homes</b> .....	<b>3.5.1</b>	Above Grade.....	2.5.1(b)
<b>Corrosion Protection</b> .....	<b>3.3.9</b>	Age.....	2.5.1(h)
Cover (ground).....	2.5.2(b)	Fittings.....	2.3.4
Curb Valve.....	2.5.3(c)	Insert.....	2.6.2, 2.6.1
<b>Definitions</b> .....	<b>1.6</b>	Joining.....	2.5.3(h)
Disconnected.....	4.3(b)1	MAOP.....	2.5.1(a)
<b>Electrical Bonding</b> .....	<b>3.3.7</b>	Sizing.....	2.4.1
<b>Electrical Grounding</b> .....	<b>3.3.7</b>	Pressure.....	3.1.4, 1.3.1(e)
<b>Electrical Isolation</b> .....	<b>3.3.7</b>	<b>Available</b> .....	<b>2.4.2</b>
<b>Establishing Gas Service</b> .....	(see also Re-	<b>Drop</b> .....	<b>2.4.3</b>
<b>establishing gas service, 4.2.3, 3.1.6,</b>	<b>1.3.2</b>	High.....	3.6.1, 1.6
<b>1.3.2</b>		Intermediate.....	1.6
Excess flow valve.....	2.5.3(a)	Low.....	1.6
Fittings		MAOP.....	1.6
<i>Adapter</i> .....	2.3.5	Medium.....	1.6
Cast Iron.....	2.3.5(b)	Plastic pipe.....	2.5.1(a)
Mechanical.....	2.3.3	Protection.....	2.5.1(e)
Plastic.....	2.3.4	<b>Corrosion</b> .....	<b>3.3.9</b>
Screw.....	2.3.5	Damage.....	3.2.5
Flooding.....	3.1.5(a)3.iii, 2.5.6(e)	<b>Heat or Ignition</b> .....	<b>3.2.6</b>
Galvanized		Vent.....	3.1.5(a)3.iv
malleable iron.....	2.3.5(a)	<b>Purge Points</b> .....	<b>4.5.3</b>
steel sleeves.....	2.2.2(c)1	<b>Purging</b> .....	<b>4.5</b>
Heating Valve.....	2.4.4	<b>air</b> .....	<b>4.5.2</b>
<b>High Pressure Regulator Settings</b> .....	<b>3.6</b>	<b>natural gas</b> .....	<b>4.5.1</b>
House Lines.....	1.1(c)	Records.....	4.5.4
Inspection and Testing.....	2.5.3(d)1, 1.4, 1.3.2(d), 1.3.2(b), 1.1(f), 1.1(c)	Reestablishing Gas Service.....	4.4
Inspection Request.....	1.3.2(d)	Regulator	
Inspection, Testing, and Purging.....	Part 4		
Insulation.....	3.3.7, 2.3.7(b), 2.3.7(a)		
<b>Interruption of service</b> .....	<b>3.1.7</b>		

**Standards for Customer Service Lines, Meters, and Service Regulators (Plumbers Guide)**

---

<b>High Pressure Settings</b> .....	<b>3.6</b>	Specific Gravity .....	2.4.4
<b>Location</b> .....	<b>3.6.2, 3.2.7</b>	Support .....	
Vent .....	3.1.5	Meter Settings.....	4.2.4(a), <b>3.3.8</b> , 2.3.6(a)
Regulators ....	3.3.2(b), 3.1.4(b), 3.1.4(a), 1.5(b),	Service Line .....	2.6.3(d), 2.5.6(b), 2.5.1(i)
1.1(a)		Testing .....	4.2.4, 4.2.2, 4.1.2(a), 1.1(a)
Repair .....	4.3(b)2, 3.2.2, 3.2.1(c), 3.1.7, 1.1(f)	<b>Thread Sealant</b> .....	<b>3.3.10</b>
Risers 3.3.4, 2.6.3(g), 2.6.3(f), 2.5.5(b), 2.5.3(a),		<b>Tracer Wire</b> .....	<b>2.5.5</b>
2.5.1(b), 2.3.6, 2.2.2(a), 2.2.1(b)		<b>Trenching</b> .....	<b>2.5.2</b>
Service Request .....	1.3.1, 1.3	Unions .....	3.3.7, 2.3.5(a)
Sizing .....	1.2(c)	Vaults .....	2.5.1(e)
<b>Meter</b> .....	<b>3.4</b>	Visual Inspection.....	<b>4.1.3</b> , 4.1.2(b), 2.5.6(a),
Service Line .....	<b>2.6</b> , 2.4	2.5.1(c), 1.3.2(d)	
Sleeve .....	2.3.6(b), 2.2.2(c)		